

**2014 European Best Practices  
Guidelines  
on  
Cargo Securing for Road Transport**

Final version 8 May 2014

**Table of Contents**

- Chapter 1 General background ..... 5
  - 1.1 Scope and objectives..... 5
  - 1.2 Applicable standards..... 6
  - 1.3 Functional Responsibilities..... 7
  - 1.4 Physical background ..... 9
  - 1.5 Load Distribution ..... 10
  - 1.6 Vehicle Equipment ..... 12
- Chapter 2 Vehicle structure ..... 12
  - 2.1 Side walls ..... 13
  - 2.2 Headboard ..... 14
  - 2.3 Rear wall ..... 15
  - 2.4 Floor ledge ..... 16
  - 2.5 Stanchions ..... 16
  - 2.6 Lashing points ..... 19
  - 2.7 Specific equipment ..... 21
  - 2.8 ISO-Containers (ISO 1496-1)..... 21
    - 2.8.1 End walls ..... 21
    - 2.8.2 Sidewalls ..... 21
    - 2.8.3 Attachment- and lashing points ..... 21
    - 2.8.4 Twist locks..... 22
  - 2.9 Swap bodies ..... 22
- Chapter 3 Packaging ..... 23
  - 3.1 Packaging materials ..... 23
    - 3.1.1 Shrink film ..... 23
    - 3.1.2 Stretch hoods ..... 24
    - 3.1.3 Stretch wrap film ..... 24
    - 3.1.4 Pre-stretched wrap film ..... 24
    - 3.1.5 Straps ..... 24
    - 3.1.6 Nets ..... 24
  - 3.2 Packaging methods ..... 25
    - 3.2.1 Form based transport packaging ..... 25
    - 3.2.2 Force based transport packaging ..... 25
  - 3.3 Packaging test methods ..... 26
- Chapter 4 Securing equipment ..... 28
  - 4.1 Lashings ..... 28
    - 4.1.1 Web lashings..... 28
    - 4.1.2 Chains ..... 29
    - 4.1.3 Steel wire ropes ..... 30
  - 4.2 Friction enlarging equipment ..... 30

4.2.1. Coating.....	30
4.2.2. Rubber anti slip mats .....	30
4.2.3. Non rubber anti slip mats.....	31
4.2.4 Anti slip sheets .....	31
4.3 Blocking bars.....	31
4.4 Filler materials .....	32
4.5 Corner protectors .....	33
4.6 Nets and covers .....	34
4.7 Other securing material .....	34
Chapter 5 Securing methods.....	35
5.1 General principle.....	35
5.2 Locking.....	35
5.3 Local blocking.....	35
5.4 Global blocking .....	36
5.5 Direct lashing .....	37
5.5.1 Diagonal lashing .....	37
5.5.2 Parallel lashing.....	37
5.5.3 Half loop lashing.....	38
5.5.4 Spring lashing .....	38
5.6 Top over lashing.....	38
5.7 General remarks on securing methods .....	40
Chapter 6 Calculations .....	41
6.1 Example 1 - wooden crate with low centre of gravity.....	41
6.1.1 Sliding.....	42
6.1.2 Cargo with mass $m$ prevented from sliding by the two top-over lashings .....	42
6.1.3 Cargo mass prevented from sliding forward by the spring lashing...	42
6.1.4 Cargo weight prevented from sliding by the two top-over lashings and the spring lashing .....	43
6.1.5 Tipping.....	43
6.1.6 Conclusion .....	44
6.2 Example 2 - wooden crate with high centre of gravity.....	44
6.2.1 Sliding.....	44
6.2.2 Cargo weight prevented from sliding by the two top-over lashings.	45
6.2.3 Cargo weight prevented from sliding forward by the spring lashing	45
6.2.4 Cargo weight prevented from sliding by the two top-over lashings and the spring lashing .....	46
6.2.5 Tipping.....	46
6.2.6 Cargo weight prevented from tipping sideways by the two top-over lashings .....	46

6.2.7 Conclusion .....	47
6.3 Example 3 - Palletized consumer goods.....	47
Chapter 7 Check of cargo securing.....	49
7.1 Classification of deficiencies .....	49
7.2. Methods of inspection .....	49
7.3. Assessment of deficiencies .....	50
Chapter 8 Examples of cargo securing arrangements for specific goods .....	51
8.1 Panels stowed on flat platform with A-frames.....	51
8.2 Timber loads .....	52
8.2.1 Sawn Packaged Timber .....	52
8.2.2 Round Timber and non-packaged Sawn Timber.....	53
8.2.3 Long poles .....	55
8.3 Large containers.....	56
8.4 Transport of mobile machinery.....	56
8.5 Transport of cars, vans and small trailers.....	58
8.6 Transport of trucks, trailers and chassis on trucks .....	60
8.7 Transport of coils .....	61
8.7.1 Coils of more than 10 ton.....	61
8.7.2 Coils of less than 10 ton .....	62
8.8 Beverages .....	63
8.9 Transport of palletized goods.....	64
8.10 Transport of palletized goods using cross lashing .....	65
8.11 Mixed loads.....	67
Appendix 1 Symbols .....	68
Appendix 2 Quick Lashing Guide.....	69
Appendix 3 Friction factors.....	90
Appendix 4 Assessment of deficiencies.....	91

## Chapter 1 General background

### 1.1 Scope and objectives

*The purpose of these guidelines is to provide basic practical advice and instructions to all persons involved in loading/unloading and securing cargo on vehicles, including carriers and shippers. They should also be useful for enforcement bodies performing technical roadside inspections in accordance with Directive 2014/47/EU and rulings of courts of law. It could also serve as a basis for Member States when taking the necessary steps for putting into practice the training of drivers, in accordance with Directive 2003/59/EC, on the initial qualification and periodic training of drivers of certain road vehicles for the carriage of goods or passengers. The guidelines aim to provide a guide for adequate cargo securing for all situations that may occur in normal traffic conditions. The guidelines should also serve as a common basis for both practical application and enforcement of cargo securing.*

During transport, all cargo items should be prevented from sliding, tipping, rolling, wandering or substantial deformation and rotation in any direction by methods such as locking, blocking, lashing or combinations of these methods. This is to protect the people involved in loading, unloading and driving the vehicle, together with other road users, pedestrians, the load itself and the vehicle.

Cargo must be placed on the vehicle so that it can neither endanger persons nor goods and cannot move on or off the vehicle.

Nevertheless, every day road incidents and accidents occur on roads because of cargoes that have not been properly stowed and/or secured. These European Best Practices Guidelines provide physical and technical background information as well as practical securing rules for road transport. For more details reference is made to international standards. They do not overwrite the extensive test results available all over Europe for specific types of cargo or specific transport conditions, nor do they describe in detail all possible solutions for all possible loads. These guidelines are meant for all persons involved in a transport chain that plan, prepare, supervise or check transport by road in order to have safe transports.

These European Best Practice Guidelines are based on the European standard EN 12195-1<sup>1</sup>. The guidelines present the current best practises in this field with focus on vehicles with a maximum mass exceeding 3.5 tonnes. When using these guidelines, one must ensure that the methods used are adequate for the particular situation at hand and where appropriate take further precautions

These European Best Practice Guidelines are intended to support the application of international rules as laid down by ADR and the Directive 2014/47/EU on the technical roadside inspections.

Additional guidelines can provide more information or alternative methods for specific cargo and/or specific vehicles, but they should not describe additional requirements or further limitations and shall always be aligned to European standard EN 12195-1.

---

<sup>1</sup> Standard EN12195-1 "Load restraining on road vehicles – Safety – Part 1 "Calculation of securing forces". At the time of elaborating these guidelines the version EN12195-1:2010 was applicable

## 1.2 Applicable standards

These European guidelines on cargo securing are based on physical laws related to friction, gravity, dynamics and strength of materials. However the daily application of such laws can be complex. To simplify the design and the check of cargo securing arrangements, specific standards related to the strength and performance of a superstructure, securing arrangements, materials used for securing, etc. can be found in the latest version of the following international standards<sup>2</sup>:

<b>Standard<sup>3</sup></b>	<b>Subject</b>
- EN 12195-1	Calculation of lashing forces
- EN 12640	Lashing points
- EN 12642	Strength of vehicle body structure
- EN 12195 -2	Web lashings made from man-made fibres
- EN 12195-3	Lashing chains
- EN 12195-4	Lashing steel wire ropes
- ISO 1161, ISO 1496	ISO container
- EN 283	Swap bodies
- EN 12641	Tarpaulins
- EUMOS 40511	Poles - Stanchions
- EUMOS 40509	Transport Packaging

National and local standards contradictory to these international standards or describing further limitations shall not be imposed for international transport.

For intermodal transport operations other requirements such as IMO/ILO/UNECE Code of Practice for Packing of Cargo Transport Units (CTU Code) may apply.

---

<sup>2</sup> For transports using vehicles up to 3.5 tonnes maximum authorised mass other standards such as ISO 27955 and ISO 27956 may apply

<sup>3</sup> Standards are usually available via the national standardisation institutes

## 1.3 Functional Responsibilities

All parties involved in the logistics process, including packers, loaders, transport companies, operators and drivers, have a role to play in ensuring that cargo is properly packed and loaded on a suitable vehicle.

It is very important to understand that responsibilities for cargo securing are based on international conventions and regulations, national legislation and/or contracts between involved parties.

A contractual agreement on functional responsibilities is advisable. In absence of such agreement between the involved parties and notwithstanding any legislation, the chain of responsibility described below identifies major functional responsibilities - related to the securing of the cargo:

### **Responsibilities/actions related to transport planning:**

1. correct description of the cargo including at least
  - a. the mass of the load and each load unit
  - b. the position of the center of gravity of each load unit if not in the middle
  - c. enveloping dimensions of each load unit
  - d. limitations for stacking and orientation to be applied during transport
  - e. all additional information that is required for proper securing
2. ensuring that load units are suitably packed to withstand the stresses which are to be expected under normal transport conditions including applicable lashing forces
3. ensuring that dangerous goods are correctly classified, packed and labelled
4. ensuring the dangerous goods transport documents are completed and signed
5. ensuring the vehicle and the securing equipment are suitable for the cargo to be transported
6. ensuring all information related to the load securing capacities of the vehicle is communicated to the loader
7. ensuring no unwanted interaction between cargo of different loaders can occur

### **Responsibilities/actions related to loading:**

1. ensuring that only cargo which is safe and suitable for transport, is loaded
2. checking if a load securing plan is available when starting to load
3. ensuring all certificates of vehicle parts used for the securing of the cargo, can be provided
4. ensuring the vehicle is in sound condition and the loading compartment is clean
5. ensuring all equipment necessary for load securing is available in a sound condition when starting to load
6. ensuring the floor of the vehicle is not overstressed during loading operations
7. ensuring that the cargo is correctly distributed in the vehicle, taking into account the load distribution on the vehicle axes and the acceptable gaps (in the securing plan if available)
8. ensuring that the vehicle is not overloaded

9. ensuring that necessary additional equipment such as anti-slip mats, stuffing and dunnage materials, blocking bars and all other securing equipment that should be fixed during loading, are properly applied (according to the securing plan if available)
10. ensuring the vehicle is properly sealed if and when applicable
11. ensure all lashing equipment is properly applied (according to the securing plan if available)
12. closing of the vehicle when applicable

**Responsibilities/actions related to driving:**

1. visual inspection of the outside of the vehicle and of the cargo if accessible to check for evident unsafe situations
2. ensuring all certificates/markings of vehicle parts used for the securing of the cargo, can be provided if necessary
3. regular checks of cargo securing during the transport journey as far as accessible

## 1.4 Physical background

The design of cargo securing arrangements has to be based on:

- Accelerations,
- Friction factors,
- Safety factors,
- Test methods.

These parameters and methods are addressed and described in the European Standard EN 12195-1.

The sum of effects of locking, blocking, direct lashing and frictional lashing are allowed to be used to prevent the cargo from moving including sliding, tilting, rolling, wandering, substantial deformation and rotation (around any vertical axis).

To simplify it to drivers, loaders and enforcement staff, cargo securing arrangements can be designed in accordance to the Quick Lashing Guide (see Annex). The number, type and method of lashing and cargo securing arrangements can be different if in accordance with the standards.

The load securing arrangement must be capable of withstanding ...

... 0,8 of the cargo weight forwards

... 0,5 of the cargo weight sideways and towards the rear

... 0,6 of the cargo weight sideways if there is risk of the load tipping

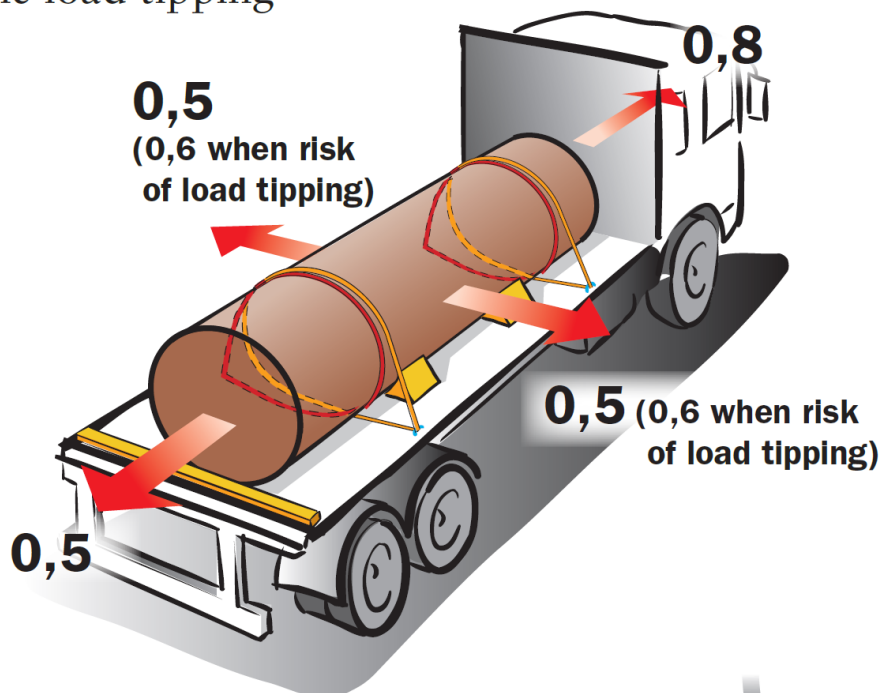

**Friction:**

Maximum friction forces are result of the contact force between two objects multiplied by the friction coefficient.

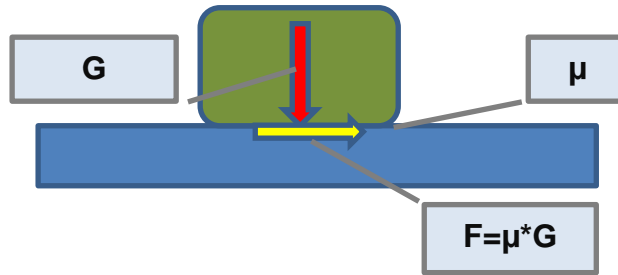

**Note:** If the contact force "G" between the two objects is reduced, also friction force will be reduced; in case that the force between the two elements becomes 0, there will be no friction force. Vertical vibrations may reduce the vertical force between cargo and the loading platform!



### 1.5 Load Distribution

When any load is placed upon a vehicle, the maximum authorised dimensions, axle and gross weights must not be exceeded. Minimum axle loads should also be considered to ensure adequate stability, steering and braking, as either foreseen by law or the vehicle manufacturer.

Transport Units are particularly sensitive to the position of the centre of gravity of the load, due to specified axle loads for maintaining steering and braking ability. Such vehicles may be equipped with specific diagrams (see examples below, figure x.x and figure x.x), which show the permissible pay load as a function of the longitudinal position of its centre of gravity. Generally, the maximum pay load may be used only when the centre of gravity is positioned within narrow boundaries about half the length of the loading space.

Load distribution diagrams should be provided by the vehicle or body manufacturer, they can also be calculated later with the vehicle's geometry, all minimum and maximum axle loads, distribution of the tare weight on the different axles as well as the maximum payload as input,

either by a spreadsheet calculation or by simple software tools. Such software is available on the internet, for free or very cheaply.

Distribution of load in accordance with the vehicles load distribution diagram will help to not exceed the maximum permissible axle loads of the vehicle.

Examples for load distribution diagram of typical 18 t 2-axle truck:

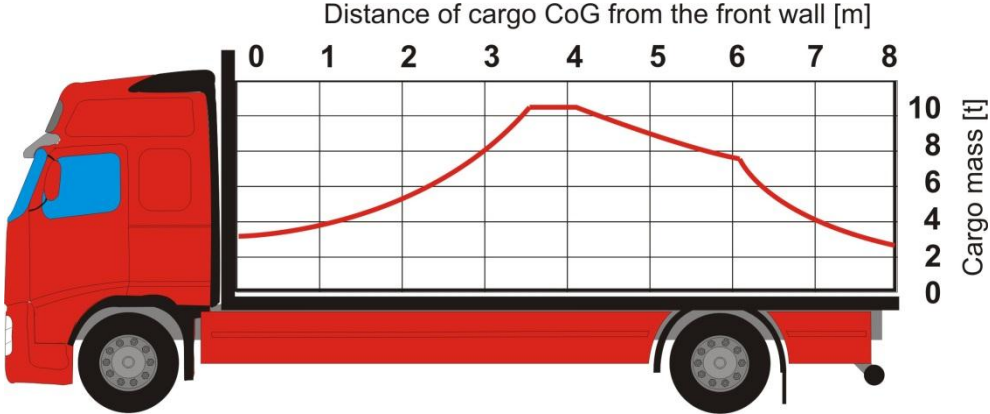

Figure X

Example of load distribution diagram of typical 13.6 m semitrailer:

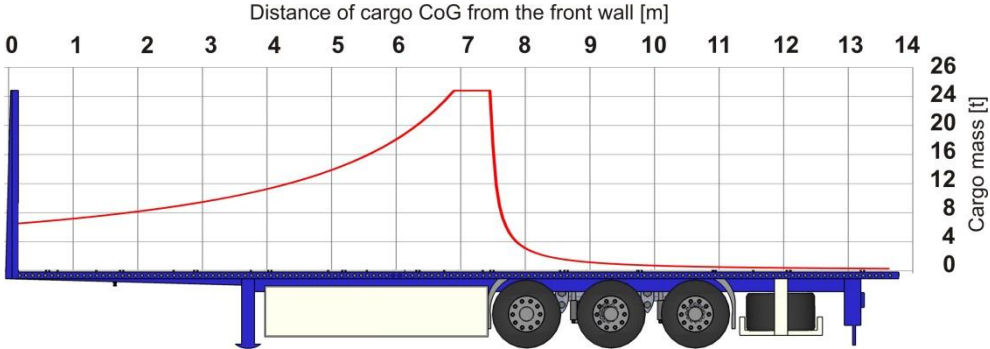

Figure XX

## 1.6 Vehicle Equipment

It should be remembered that any accessories or equipment, either permanently or temporarily carried by the vehicle, are also considered part of the load. The damage that an unsecured landing leg can cause if it extends while the vehicle is in motion is enormous as some fatal experiences have shown.



Loose equipment, such as webbing, ropes, sheeting etc., should also be carried in a manner so as not to endanger other road users. Good practice is to have a separate locker in which to safely store these items when not being used. If, however they are kept in the driver's cab, they must be stowed in such a manner that they cannot interfere with any of the drivers controls.

## Chapter 2 Vehicle structure

The European standards EN 12640, EN 12641, EN 12642 and EN 283 provide requirements for vehicle structure and lashing points of cargo transport units (CTU), vehicles and swap bodies as described below.

The amount of cargo securing arrangement in the different CTU's depends on the type of cargo as well as the strength in side walls, headboard and rear wall.

Comparison of strength requirements of CTU side walls, headboard and rear wall.

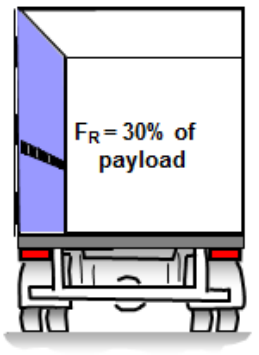
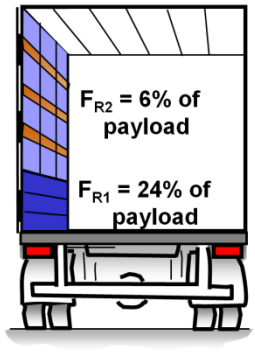
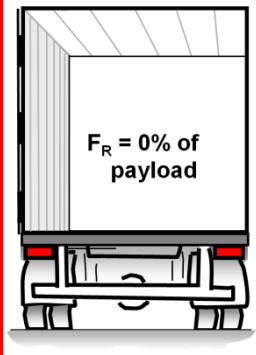
	BOX-TYPE VEHICLE	COVER/STAKE VEHICLE (WITH HINGED DROPSIDES)	CURTAINSIDER
			
EN 12642 L	 $F_R = 30\%$ of payload	 $F_{R2} = 6\%$ of payload $F_{R1} = 24\%$ of payload	 $F_R = 0\%$ of payload

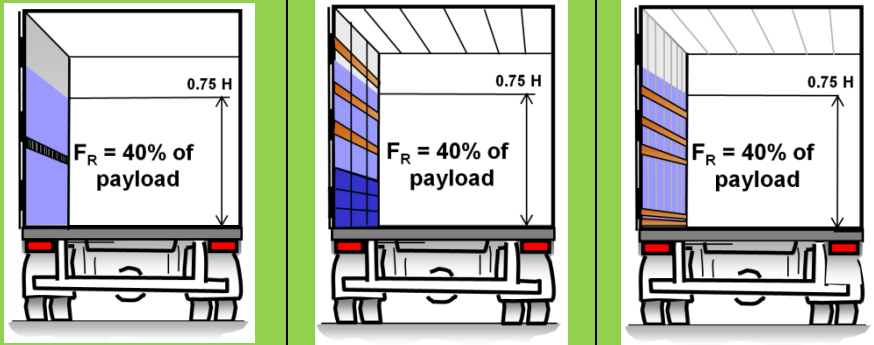
	<p><b>Headboard:</b> <math>F_R = 40\%</math> of payload P, maximum 5000 daN</p> <p><b>Rear wall:</b> <math>F_R = 25\%</math> of payload P, maximum 3100 daN</p>
EN 12642 XL	 <p><b>Headboard:</b> <math>F_R = 50\%</math> of payload P</p> <p><b>Rear wall:</b> <math>F_R = 30\%</math> of payload P</p>

The vehicle types marked in green have strong side walls, the yellow marked vehicles have sides for bottom blocking only and the sides of the red marked vehicles are to be regarded as weather protection only. Below the practical use of the different strengths are described.

**Note** that if the side walls are used for blocking of cargo it is important that the type and number of laths according to the test certificate is used. The laths are to be placed so that the cargo weight is distributed to the load-bearing parts of the side walls; stakes, roof beam and floor.

## 2.1 Side walls

The vehicles are grouped into the following categories depending on the strength in the side walls:

- EN 12642 XL with strength 40 % of payload (0.4 P)
- EN 12642 L with strength 30 % of payload (0.3 P)
- No strength at all; 0 % of payload

### - Side walls - EN 12642 XL

If the side walls are built according to EN 12642 XL the side walls are tested to take up a force corresponding to 40 % of the payload (0.4 P) uniformly distributed over the length and at least 75% of internal height of the sidewall. The design acceleration sideways is 0.5 g. Thus, if the friction factor is at least 0.1 the side walls are strong enough to withstand the sideway forces of a full payload.

### - Side walls - EN 12642 L

If the side walls are built according to EN 12642 L the side walls in a box trailer are tested to take up a force corresponding to 30 % of the payload (0.3 P) uniformly distributed over the length and height of the sidewall. The design acceleration sideways is 0.5 g. Thus, if the friction factor is at least 0.2 the side walls are strong enough to withstand the sideway forces of a full payload.

**Note** that side walls in a curtainsider built according to EN 12642 L is regarded as a weather protection only.

– **Side walls - No strength**

When cargo is transported in a cargo transport unit without strong sides, the whole cargo weight has to be secured against sideway movements by lashings according to the Quick Lashing Guide.

## 2.2 Headboard

The following strength in the headboard is possible:

- EN 12642 XL with strength 50 % of payload (0.5 P)
- EN 12642 L with strength 40 % of payload (0.4 P), maximum 5 000 daN
- Unmarked CTU or cargo not stowed tightly against the headboard, 0 % of payload.

*Friction factors are according to EN 12195-1:2010.*

– **Headboard - EN 12642 XL**

If the headboard is built according to EN 12642 XL the headboard is able to take up a force corresponding to 50 % of the payload (0.5 P). The design acceleration in forward direction is 0.8 g. Thus, if the friction factor is at least 0.3 the headboard is strong enough to withstand the forces in forward direction of a full payload.

– **Headboard - EN 12642 L**

Headboards built in accordance with EN 12642 L are able to withstand a force corresponding to 40 % of the vehicles payload (0.4 P). However, for vehicles with a payload of more than 12.5 tons, the strength requirement is limited to a force of 5 000 daN. With respect to this limit the table below shows the cargo weight in tons that is permitted to be blocked against a headboard with a limited strength of 5 000 daN for different friction factors. If the cargo mass is larger than relevant table value additional securing arrangements are required.

Friction factor $\mu$	Cargo mass possible to block against the headboard in forward direction (ton)
0.15	7.8
0.20	8.4
0.25	9.2
0.30	10.1
0.35	11.3
0.40	12.7
0.45	14.5
0.50	16.9

0.55	20.3
0.60	25.4

– **Headboard - No strength**

When cargo is transported in a cargo transport unit with a headboard with no strength or when it is not stowed tightly against the headboard the whole cargo weight has to be secured against forward movement by e.g. lashings according to the Quick Lashing Guide.

## 2.3 Rear wall

The following strength in the rear wall is possible:

- EN 12642 XL with strength 30 % of payload (0.3 P)
- EN 12642 L with strength 25 % of payload (0.25 P), maximum 3 100 daN
- Unmarked CTU or cargo not stowed tight against the rear wall, 0 % of payload

*Friction factors are according to EN 12195-1:2010.*

– **Rear wall - EN 12642 XL**

If the rear wall is built according to EN 12642 XL the rear wall is able to take up a force corresponding to 30 % of the payload (0.3 P). The design acceleration in backward direction is 0.5 g. Thus, if the friction factor is at least 0.2 the rear wall is strong enough to withstand the forces in backward direction of the full payload.

– **Rear wall - EN 12642 L**

Rear walls built in accordance with EN 12642 L are able to withstand a force corresponding to 25 % of the vehicles payload (0.25 P). However, for vehicles with a payload of more than 12.5 tons, the strength requirement is limited to a force of 3 100 daN. With respect to this limit the table below shows the cargo weight in tons that is permitted to be blocked against a rear wall with a limited strength of 3 100 daN for different friction factors. If the cargo mass is larger than relevant table value additional securing arrangements are required.

Friction factor $\mu$	Cargo mass possible to block against the rear wall in backward direction (ton)
0.15	9.0
0.20	10.5
0.25	12.6
0.30	15.8
0.35	21.0
0.40	31.6

– **Rear wall - No strength**

When cargo is transported in a cargo transport unit with a rear wall with no strength or when it is not stowed tightly against the rear wall, the whole cargo weight has to be secured against backward movement by lashings according to the Quick Lashing Guide or to alternative instructions if equivalent safety could be verified.

## – Securing against doors

When doors are designed to provide a defined blocking resistance the doors may be considered as a strong cargo space boundary, provided the cargo is stowed to avoid impact loads to the doors and to prevent the cargo from falling out when the doors are opened.

## 2.4 Floor ledge

Floor ledge is very helpful to prevent from sliding off the platform in lateral direction. According to EN 12642:2006 their height should be at least 15 mm and withstand a force corresponding to 0.4 Payload (P).

## 2.5 Stanchions

Stanchions are often very useful for load securing. They can be welded on the vehicle superstructure, but most often they are mounted in specific holes in the superstructure.

Stanchions are used at both sides of the vehicle to secure loads in transverse directions by blocking (see chapter 5). Some poles on a line in the longitudinal direction in the middle of the width of the loading platform are very useful, e.g. for a combination of blocking and loop lashing as explained in paragraph 8.2 (picture). In many vehicles poles can also be used for blocking in the forward direction. One or more poles are placed just in front of the load. A lashing could preferably be used in the top to support the poles.

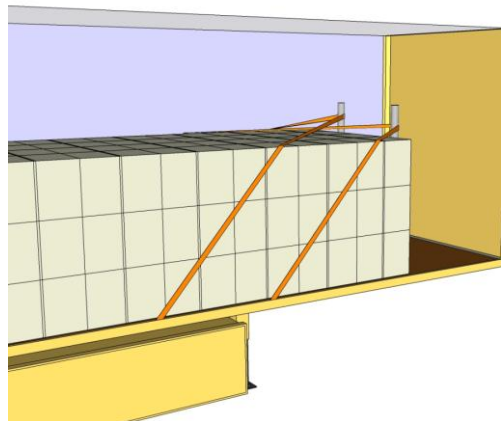

Picture X

A stanchion can be used for blocking, one of the methods for cargo securing. To use this method the capacity of a pole to resist to forces should be known. This capacity depends on the type of load (point load, distributed load or mixed) and on its leverage. The reference blocking capacity (RBC) in a certain direction of a mounted pole is the maximum safe uniform distributed load on the bottom 1m of that pole. This means the RBC takes into account the strength of its mounting. The reference blocking capacity can be used to check if the pole can resist to a known specific force with a specific leverage. The formulas to calculate the maximum force  $F_{\max}$  in case of a distributed force or in case of a point load, are shown in picture...

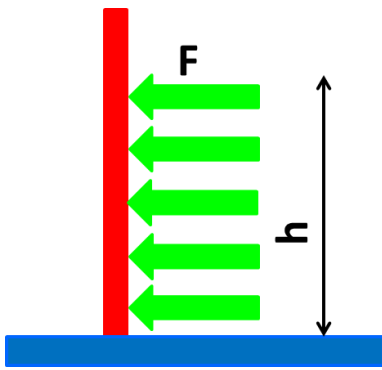

$$F_{\max} = \frac{\text{RBC}[\text{daN}] * 1[\text{m}]}{h[\text{m}]}$$

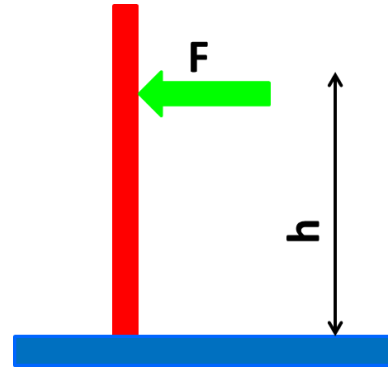

$$F_{\max} = \frac{\text{RBC}[\text{daN}] * 1[\text{m}]}{2 * h[\text{m}]}$$

The RBC of stanchions varies from 250 to 10000daN and is very difficult to estimate since it depends on the material strength, on the dimensions of its section and on the strength of its mounting. Therefore, the RBC should be certified by the vehicle constructor. Stanchions should not be used on other types of vehicles than the vehicle type they are designed and tested for

The blocking capacity RBC of a mounted stanchion does not depend on the height of the pole as long as the section of the pole is the same. Stanchions of different heights can be used and no additional test nor certificate is necessary.

In some cases stanchions are connected, e.g. two stanchions, each at one side of the vehicle are connected at their top by means of a chain. The total blocking capacity of the complete system including the two stanchions and the chain, has to be tested and cannot be calculated based on the blocking capacities of both poles separately.

Examples for Calculation of stanchions:

Example 1: Two tubes of the same mass, diameter of 1.2 m. There are two pairs of stanchions, each of an RBC of 1800 daN. What is the maximum mass of the tubes these stanchions can bear within this configuration? These tubes apply a point load. Hence, the right one of the the two formulas above has to be selected.

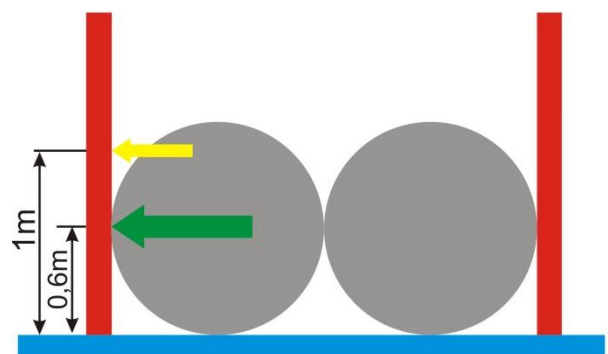

$$F_{\max} = \frac{2 * 1800 [\text{daN}] * 1 [\text{m}]}{2 * 0,6 [\text{m}]} = 3000[\text{daN}]$$

Hence, the maximum force  $F_{\max}$  is 3,000 daN. Considering the fact that a tube is a load, which is in danger of tipping, the applicable limit for sideward movement is 0.6 g.

$$3,000 / 0.6 = 5.000$$

Roughly speaking, the two tubes together may have a maximum mass of 5 tons.

Example 2: Many tubes, piled up to a height of 1.3 m.

There are two pairs of stanchions, each of an RBC of 1800 daN. What is the maximum mass of the tubes these stanchions can bear within this configuration? These tubes apply a distributed load, hence, the left of the two formulas above has to be applied.

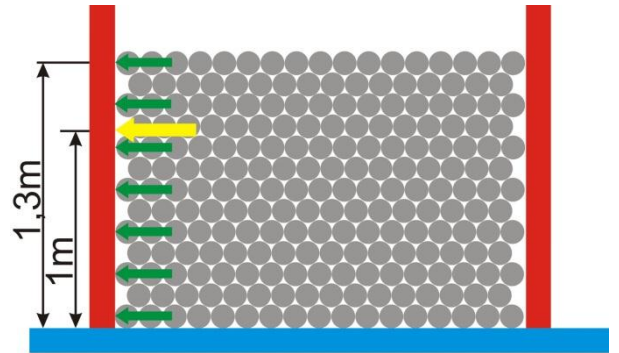

$$F_{max} = \frac{2 * 1800 \text{ [daN]} * 1 \text{ [m]}}{1.3 \text{ [m]}} = 2769 \text{ [daN]}$$

Hence, the maximum force  $F_{max}$  is 2.769 daN. Considering the fact that a tube is a load, which is in danger of tipping, the applicable limit for sideways movement is 0.6 g.

$$2.769 / 0.6 = 4.615$$

Roughly speaking, these tubes together may have a maximum mass of 4.6 tons.

## 2.6 Lashing points

A lashing point is a specific securing device on a vehicle to which a lashing, chain or steel wire may be directly attached. A lashing point can be e.g. an oval link, a hook, a ring, a lashing shoulder.



An anchorage point is a more general term. Anchorage points include lashing points, the vehicle body structure and rails or planks for fixation of stanchion bars, blocking boards, ...

Lashing points in load carriers should be placed in pairs, opposite each other, along the long sides with a spacing of 0.7 – 1.2 m longitudinally and a maximum of 0.25 metres from the outer edge. Continuous lashing anchorage bars are preferable. Each lashing point should at

least withstand the following lashing forces, within the boundary conditions of standard EN12640,:

Table x.x

Vehicle total mass in tonnes	Strength of lashing point in daN
3.5 to 7.5	800
above 7.5 to 12.0	1.000
above 12.0	2.000*

\*(in general 4.000 daN is recommended)

Lashing points in sound condition on a vehicle in sound condition are considered to meet the requirements mentioned in table above, even if no certificates are available.

Below, lashing attachments are shown in the form of fixed tensioner as well as hooks fitted to the load carrier.

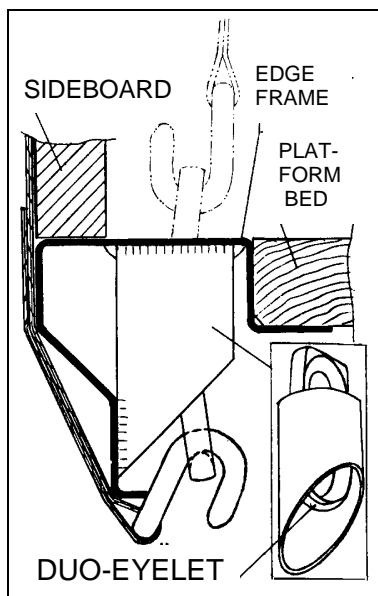

Lashing eyelet

- A tensile load, higher than the values mentioned in table x.x, is permissible in all directions or in a specific direction if the lashing point is certified according to the standard and appropriate marking is available on the vehicle.
- The permissible load on a fixed lashing point can be significantly lower than the strength of the lashing point itself. When using a lashing point one should clearly distinguish between a certificate of the lashing point and a certificate of the fixed lashing point according to EN12640. Some lashing points are certified for lifting purposes but do almost not resist to forces in the direction of a lashing.
- Lashing points used for lashing of heavy pieces of cargo are a major concern. In some cases several chains or lashings are used to restrain a heavy load in one direction. Each chain or lashing to restrain the load in that direction, is fixed on one lashing point. In most cases inertia forces will cause unequal forces on these lashing points. The use of one single rigid lashing point is preferred.
- In some cases ratchet type of lashing points are mounted on the body structure. They do not comply with EN12640 nor with EN12195-2. Since they are available in different sizes and qualities, a general minimum strength is not known. They can be used according to the specifications of their test certificate.

The vehicle body structure should be considered as very rigid and can resist high forces. Therefore, in some cases this structure can be used for load securing in combination with appropriate securing equipment such as:

- The longitudinal beam at the left and right side under the loading platform of most vehicles, can be used to fix an appropriate hook for top-over lashing and loop lashings. The number of lashings attached to the longitudinal beam and their total lashing force should be reasonable in order to avoid deformation of the vehicle body.
- Structural parts of a “deeploader” can be used to fix chain hooks.

Other anchorage points can be used according to the guidelines of the producer and according to the certified loads they can resist to.

- Anchorage holes in the left and right profiles of the loading platform can resist to high forces in most directions. If no guidelines of the producer are available, 2 anchorage holes per meter can be loaded with the forces mentioned in table x.x.



- Rails in the loading platform, in the roof of the vehicle and in the sidewalls can resist high forces in the longitudinal direction, but do almost not resist forces transverse to the surface they are fixed to. Therefore, they should not be used in combination with lashings unless specified otherwise by the producer. They should be used with specific blocking bars within the specifications of the test certificate. Common types of blocking bars and their limitations are described in paragraph 4.3.

## 2.7 Specific equipment

For some types of cargo, purpose built vehicles are used, including specific cargo securing equipment. The manufacturer should certify the strength of the vehicle according to EN12642 and specific equipment according to EN12195-2 to 4. Such a vehicle and equipment should be used according to the guidelines of the manufacturer.



For abnormal transports, cargo securing can be very complex and can require an analysis by an expert. Deformation of the vehicle, of the cargo itself and of the securing equipment can cause unexpected forces, especially during maneuvers.

## 2.8 ISO-Containers (ISO 1496-1)

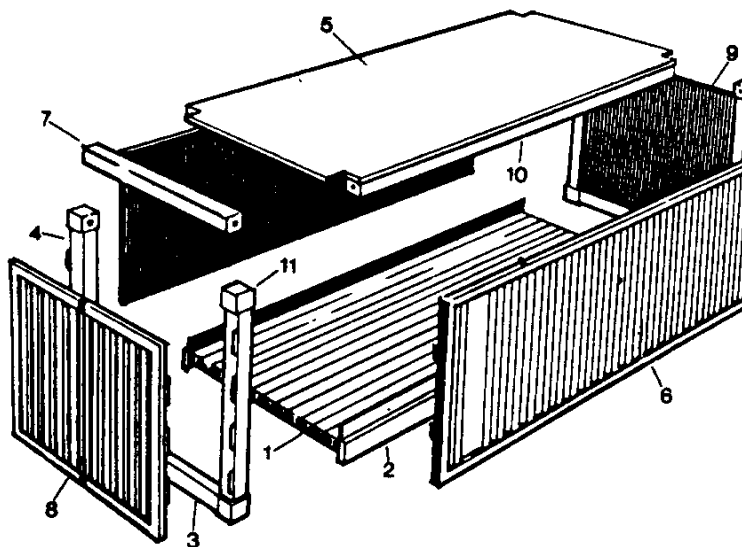

- 1 Floor
- 2 Base member
- 3 Door sill
- 4 Corner pillar
- 5 Roof
- 6 Wall trim
- 7 Upper door frame
- 8 End door
- 9 End wall
- 10 Roof member
- 11 Gusset fitting

Picture 1 Exploded view of the design and construction of the container

### 2.8.1 End walls

According to the ISO standard, both the front and rear walls (rear doors) must withstand an internal load (force) equivalent to 40% of the maximum cargo weight, evenly distributed over the entire end wall surface (door surface).

### 2.8.2 Sidewalls

Sidewalls must withstand an internal load (force) equivalent to 60% of the maximum cargo weight, evenly distributed over the entire wall.

### 2.8.3 Attachment- and lashing points

Most general cargo containers have a limited number of lashing rings or bars. When lashing rings are fitted, the anchor points at the bottom have a lashing capacity of at least 1000 daN in any

direction. Recently built containers have, in many cases, anchor points with a lashing capacity of 2000 daN. The lashing points at the top side rails have a lashing capacity of at least 500 daN.

### 2.8.4 Twist locks

Twist locks are very well known to fix a container on a container trailer. Basically, a twist lock consists of a pin that is placed in a hole in the cargo. Movement of the cargo is impossible due to the shape of this connection. For safety reasons, a system to prevent loosening of the locking, should always be used.



Even for ISO containers several designs are available, either retractable or non-retractable, either automatic or manual operated. Twist locks can also be used for other container type cargo. Some vehicles to transport crates with gas bottles use twist locks to secure the crates on the loading platform.

### 2.9 Swap bodies

The load force values for swap bodies are outlined in standard EN283. This almost corresponds with the body structure standard for carriers in standard EN12642 code L (see section 2.1 – 2.3 above).



## Chapter 3 Packaging

### 3.1 Packaging materials

Cargo to be transported by road is often packed. The CMR convention does not enforce packaging, but relieves the carrier of his or her liability for loss or damage if the cargo is not properly packed. Depending on the type of product and the mode of transport, the main function of the packaging can be: weather protection, support the product during loading and unloading, prevent product damage, enable efficient load securing,

For large products (e.g. machinery) a dedicated packaging is used. This can be a platform to support the products and a cover that can be either rigid or flexible.

For smaller products different levels of packaging are being used:

- Primary packaging is the packaging that encloses the products such as cans, boxes for biscuits, bottles for beverages, ...
- Secondary packaging can be used to facilitate handling and manipulation: trays containing 12 boxes of biscuits, crates with 24 bottles, ... Secondary packed products are often called “bundled products”.
- Tertiary packaging, often called transport packaging. This packaging level should enable safe and easy manipulation and transport. Transport packaging includes pallets (wooden, plastic, mixed materials, ...), interlayer sheets (corrugated board, hardboard, anti-slip sheets, coated paper, multiplex board, ...), edge protectors (carton or multi-material), straps (PE, PP, PET, glass fiber or steel), film (stretch hood, wrapped stretch film, shrink film), boxes (corrugated board, plastic, aluminum, wood or steel). Also different types of glue and dunnage materials are classified as transport packaging.

The transport packaging should resist to the external forces on the load unit. The magnitude, place and duration of these forces depend on the load securing method that is being used. This means that the rigidity of the transport packaging strongly influences the recommended load securing method. If the transport packaging is not strong enough to keep the load unit in shape under the forces that occur during transport, the “overall blocking” method should be used.

The rigidity of a load unit strongly depends on all levels of the packaging: secondary packaging, primary packaging and the product itself can influence the behavior of a load unit (e.g. a load unit of PET bottles behaves much more flexible if the bottles are filled with still water than with sparkling water). Nevertheless transport packaging is considered to rigidify a load unit. Box type transport packaging is designed to resist to specific horizontal forces as specified by the producer. Also proper application of straps and/or film can rigidify most load units.

Specific materials for transport packaging that can help to rigidify a load unit, are described below.

#### 3.1.1 Shrink film

Shrink film is a rather thick special type of film that is available as hoses or as flat film on a roll. A hose that is larger than the load unit to be packed is pulled over the unit. Flat film can be wrapped around the load unit. The film around such a load unit is heated up most often by using hot air. This specific type of film will shrink around the load unit. If applied properly, shrink film can be very effective to rigidify a load unit. It is often used for bricks, some bagged fertilizers, ... The use of shrink film in Europe is decreasing, mainly because of the relatively high cost and the risk for fire during application. The main advantage of a shrink film is that it can be applied manually and can be shrunk by using a simple gas burner.

### 3.1.2 Stretch hoods

A stretch hood consists of film material that retracts after being stretched. It is used as a hose that is smaller than the load unit. A specific machine is to be used to stretch the hose and pull it over the load unit. This concept has been developed as a weather protection for the load units that can be applied automatically at high speeds. Manual application is not possible since the forces to stretch the film are too high. A stretch hood can rigidify a load unit very well if well designed and well applied. For layered products the stretch hood should be stretched in the vertical direction during application. High speed, automated application, perfect weather protection and cheaper than shrink hoods are the main advantages. The main disadvantage is the low flexibility: every size of load unit requires its own hood size and its own application parameters. A hood that is some cm larger than optimal, does almost not rigidify the load unit.

### 3.1.3 Stretch wrap film

Stretch wrap film is very thin film (10 to 30 micron) mostly delivered on reels of 50cm width. It is wrapped around a load unit by a stretch wrap machine that stretches the film twice. The first stretch is between two rolls on the wrapping machine, the second stretch between the second roll and the load unit. Apart from the first and second strain, many more parameters are important to obtain a rigid load unit: overlap, number of revolutions as a function of the height, wrapping speed, percentage of roping, film type, Stretch wrap film can rigidify almost all types of load units by choosing the most appropriate parameters. The main disadvantages are that proper manual application is not possible, a perfect weather protection is impossible and the required parameters can differ considerably for slight changes of the packed products.



### 3.1.4 Pre-stretched wrap film

Pre-stretched wrap film is the most frequently used type of film for transport packaging. It is mostly sold on reels of 50cm width and is quite similar to stretch wrap film that has been stretched between two rolls. It is wrapped around a load unit manually or by a very simple wrapping machine. When the film is manually applied, the second strain is missing: there is almost no force between the load and the film. This can avoid columns of products to collapse, but it does not avoid layers to slide. Therefore pre-stretched wrap film should not be used to manually rigidify load units.

### 3.1.5 Straps

Straps are well known and do exist in PP, PET, PE, steel and glass fiber reinforced materials. They can be applied manually or automatically in horizontal plane or in a vertical plane around the load unit. The effect of straps strongly depends on the products to be rigidified. They are very useful to avoid tilting of parts of the load. They can avoid sliding by pushing layers together and thus increasing friction. However the straps should be tensioned very well. In many cases straps tend to damage the products unless appropriate corner protection is applied. The main advantage of straps is the very low cost; the main disadvantage of PP, PET and PE straps is that they tend to loose tension in time. Care should be taken to avoid dangerous situations when cutting straps.

### 3.1.6 Nets

Nets can be used to keep products on a pallet. The main advantage of a net compared to film and straps is that a net can be opened to remove or add some products and can easily be closed

afterwards. Although some smart systems exist to tension the net around the product and tighten the products on a pallet, it is almost impossible to prevent deformation due to the inertia forces during road transport. Except for the combination of a specific net for a specific class of products, it cannot be assumed that a net is a suitable solution for transport packaging.

### **3.2 Packaging methods**

In the context of load securing and rigidity of load units, two basic packaging methods are used to prevent excessive deformation of load units: form based and force based packaging. Form based packaging is often preferable for safety reasons but is not always economically feasible.

#### **3.2.1 Form based transport packaging**

Products are placed in a rigid container type enclosure and all gaps – if any- are filled to prevent movement of the products within the container. The walls of the container can be closed or can have an open structure. Walls can be fixed or are foldable. Steel type containers are often designed to carry specific types of products (e.g. in automotive industry). Plastic box pallets are a combination of a pallet and a box. A corrugated rectangular, hexagonal or octagonal box fixed on a wooden or plastic pallet is frequently used. Wheel containers are used in distribution and several industrial sectors and can have swivel or fixed wheels.

Producers of this box like transport packaging should specify the safe maximum horizontal, distributed static force the walls of the box can resist without further support of these walls. As long as the effective force on the walls of the box - resulting from the maximum inertia forces during transport - is lower than this safe maximum force, the box can be secured like the other rigid containers.

In many cases all movements of products in the container are prevented to avoid product damage. However, even if product damage is not to be expected, all movements of products in the container should be prevented for reasons of transport safety. Kinetic energy built up during movement can result in a high impact force on the wall of the container. Even if the container resists this force, it might endanger the stability of the vehicle.

#### **3.2.2 Force based transport packaging**

Packaging by means of film and/or straps is considered as force based, even though other effects can assist in the reinforcement.

When subjected to horizontal inertia forces, a product tends to slide and tilt. Often several layers of bundled products or bags are put on a pallet. In that case several failure modes can occur and the transport packaging should provide the forces to prevent these failure modes.

- sliding of all layers over the pallet: can be prevented by increasing friction between pallet and load and/or by using proper film in the top zone of the pallet and the bottom zone of the load. In some cases sliding is prevented by kegs (e.g. crates with beer on plastic or wooden pallets) or by using a pallet board (thus turning force based packaging into form based). Prevention of sliding by using film is almost impossible, if friction between the pallet and the load is low (and if the pallet is loaded with significant “underhang” (load is smaller than the pallet).
- sliding between layers can be prevented by increasing friction, by using proper film, by applying glue between layers. Layers can be clicked onto another layers (e.g. the case of beverage crates) Interlayer sheets with high friction are available on the market. Note that interlayer sheets of non -treated corrugated board or hard board tend to increase the risk of sliding.

- lifting up of one or more layers. If sliding as such is prevented, one or more layers can tilt around one of the bottom edges of that layer. As a result of this lifting up effect, friction between layers becomes zero and some click-on systems do nevertheless release, resulting in an almost unlimited deformation of the load unit. Lifting up can be prevented by straps or by proper applied film.
- Even if sliding and tilting are prevented, the tendency to slide and tilt will remain. This can lead to high compressive vertical forces in some zones of the load, resulting in a sudden collapse of the product itself or of the primary or secondary packaging. This failure mode can only be prevented by a modification of primary and/or secondary packaging. It is important to notice that top-over lashing (see chapter 5) will increase the risk of such a type of collapse.
- In layer tilting: all the products in a layer tend to tilt simultaneously in the same direction. The foot print of that layer increases slightly. This means that this failure mode can be prevented by proper pulling forces around that layer. If the secondary packaging is rigid enough, these pulling forces can be created by appropriately tensioned film or straps. The better method however is to modify the stacking pattern or to modify the primary/secondary packaging.
- Breaking: it is well known that inertia forces are proportional to the mass of the products to be retained. The lower the position in a pallet, the higher the inertia forces on the higher zone. On the other hand also the retaining forces of the packaging film are often higher in the bottom zone of the pallet. If the retaining force of the packaging is not proportional to the inertia forces, a pallet load can break into two parts. This can be prevented by increasing the quality of the packaging in that zone (increase film strength and/or friction).

Minor changes in primary, secondary or transport packaging can cause a switch to another failure mode. To prevent all these failure modes forces can be applied to the load by film and/or straps:

- Downward forces increase the contact forces between layers and between the bottom layer and the pallet. These contact forces are proportional to the friction in a horizontal plane.
- Circumferential force at a specific height prevents an increase of the footprint at that height.
- Theoretically relative movements of layers can also be prevented by the shear forces in film.

Since friction between layers and between individual products or bundles is not known and is influenced by local deformation of materials, and since dynamic effects on deformable loads are very complex, the required interaction forces between film/straps and load cannot be calculated. The rigidity of a specific load unit cannot be estimated by (visual) inspection nor by measurement of forces in transport packaging.

### 3.3 Packaging test methods

The rigidity of a load unit can be tested by doing a type test. Since all load units tend to deform, an acceptable deformation has been described in detail in specific packaging standards. Also, the method to quantify different types of deformation is described in detail. The most important deformation is measured in a plane that is parallel to the loading platform and calculated as a percentage of the height of the load unit (when standing on a horizontal floor). This elastic deformation shall be less than 10%, this permanent deformation after the test shall be lower than 6 cm and lower than 5%. Products, primary and secondary packaging shall not show any permanent deformation or damage.

Any of the following three test methods can be used:

- In an inclination test the loading platform is tilted. A tilting angle of 26.6° corresponds to an inertia force of 0.5g and a tilting angle of 38.7° corresponds to 0.8g (simple static approach according to EN12195-1).
- An acceleration test at pallet level applies inertia forces for at least 0.3s. A shorter duration of the inertia forces might not result in the maximum steady state deformation of the deformable load unit. To include the dynamic effects in the test, the acceleration should be applied within 0.05s. (dynamic approach according to EUMOS40509)
- An acceleration test at vehicle level. The load unit is put on a vehicle that is driven on a S-curve to generate an inertia force of 0.5g including the dynamic effect. An emergency brake is performed to generate an inertia force of 0.8g. More detailed requirements and the measurement method are described in the European standard. (dynamic approach according to EN12642)

# Chapter 4 Securing equipment

## 4.1 Lashings

For road transport web lashings or chains are being used most frequently. Steel wire ropes do have advantages for specific types of cargo.

All these types of lashings can transfer tensile forces only. The maximum allowable tensile force is expressed as LC, i.e. lashing capacity. This is a portion of the breaking strength and is indicated in units of force, i.e. kilo-Newton (kN) or deka-Newton (daN).

### 4.1.1 Web lashings

EN12195-2 describes web lashings of man-made fibres. They can be built as one whole or as two parts. Most often they do have a ratchet system to tension the lashing, either by pulling or pushing on the handle of the ratchet. The ratchet shall always be blocked during transport.

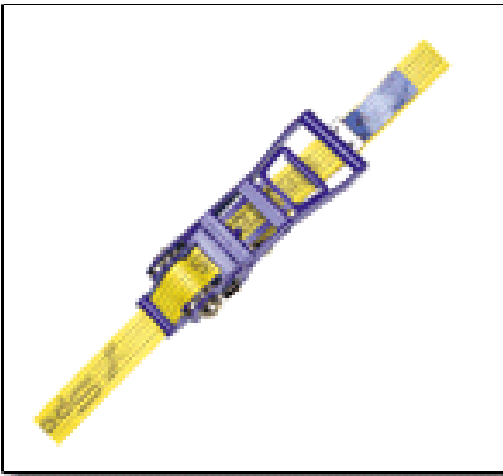

The ends of the lashing can have different types of hooks or rings to properly fix the lashing in or on lashing points on the vehicle or on the cargo. (picture)

They shall be used according to the specifications of the producer. For most types of cargo the material of the webbing itself is not important.

The web lashing material is mentioned on the label. Another important marking is the STF value, the Standard Tension Force. This is the tension force in the lashing after tensioning the ratchet with the hand force SHF 50 daN when the lashing is tensioned linearly between two points. The real tension force can be

different than the STF; higher or lower.

Other information that should be mentioned on the label, are indicated in [picture X](#).

Many producers do mention two values for LC. Only the lowest value is defined in the standard and should be used in the formula of the calculation in chapter 6. It is almost impossible to estimate visually the STF and LC value of a web lashing. Therefore the label is necessary.

Some web lashings are designed to be tensioned by a winch that is fixed on the vehicle, most often under the loading platform. [\(picture\)](#)



Special care should be taken in order to avoid damage of the web lashing itself as well as its label. A tensioned lashing can easily be cut by sharp corners of the vehicle or the cargo. Edges of steel profiles or plates, sharp concrete edges, even edges of some hard plastic crates, etc. shall not be in direct contact with a web lashing. Protective sleeves to slide over the lashing and to be positioned on the sharp edges are available on the market [\(picture\)](#). As an alternative, corner protectors can be used.

The actual tension (FT) in a lashing can be measured. Some lashings are sold with a built in tension indicator that allows a rough estimate of the actual tension force. General purpose, manually operated, measuring devices for lashings with a width of  $\pm 50$  mm are also available, allowing a measurement of the actual tension force with an accuracy that is better than 50daN (picture X). It can be mounted on a tensioned lashing for measurement. An electronic version of this measuring device with a higher accuracy is also available. Also standard load cells can be used to check real tension forces, but they can only be mounted simultaneously with the lashing.

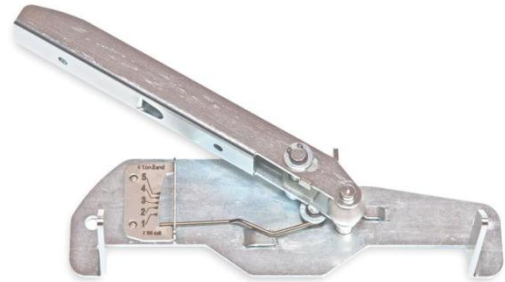

Professional transport companies most often use PES web lashings with a width of 50mm, with STF values between 250 and 500 daN and LC values between 1600 and 2000 daN. The actual tension in a lashing that has been tensioned with the ratchet varies between 0 and 600 daN. Web lashings with STF values of 1000 daN and LC values of 10000 daN are available but are not used very often.

For calculation purposes the actual tension FT shall be measured on the tensioner side.

#### 4.1.2 Chains



EN12195-3 describes chains that can be used for lashing cargo for road transport. These chains are most often short link chains with

specific hooks or rings to be fixed on the vehicle and/or the cargo. The major difference with lifting chains is a tensioning device. This tensioning device can be a non-removable part of the chain (picture...), or can be a separate device that is fixed somewhere along the chain that has to be tensioned (picture...). Several designs of tensioning devices are available on the market, such as a ratchet type and a turn buckle type. EN12195-3 specifies that the tensioning devices should have facilities that prevent loosening. Tensioning devices that have a back-lash after the tensioning of more than 150 mm are forbidden.

Chains should have a label mentioning the LC value. The maximum value of LC for class 8 can be found in the table.

Chains are very suitable to connect a lashing point on the cargo with a lashing point on the vehicle whereby the chain does not touch any other parts. In some cases, chains do touch vehicle edges or product edges. Since chains do not easily slide over corners, such chains might not be tensioned all along their length. A specific device to enhance sliding of a chain over a corner might be helpful.

Nominal chain diameter in mm	Maximum lashing capacity in daN
6	2200
7	3000
8	4000
9	5000
10	6300
11	7500
13	10000
16	16000
18	20000
20	25000
22	30000

Chains, including different types of hooks, should be used according to the specifications of the producer. An open hook is meant to be fixed in a ring that is designed for that purpose, never in a conventional link of a chain. A trimming hook is meant to be hooked over a link of a chain.

Damaged chains should be no longer used and taken out of circulation. Also the strength of a worn out chain is unreliable. As a rule of thumb, a chain is worn out as soon as its length is more than 3% longer than its theoretical length.

#### 4.1.3 Steel wire ropes

EN12195-4 describes steel wire ropes that can be used for lashing. Steel wire ropes are tensioned by means of winch type tensioners fixed on the vehicle, by separate ratchet type tensioners, by short web lashings with a ratchet tensioner. Steel wire ropes are especially suitable for securing steel building mats. The LC value of steel wire ropes is indicated by the producer.



#### 4.2 Friction enlarging equipment

High friction material can be used to increase friction between the platform bed and the cargo, and also between cargo layers when required. There are different types of high friction material, for example coatings, carpets, rubber mats and sheets of paper (antislip-sheets) covered with friction material. They can be used in conjunction with other securing methods. Friction enlarging equipment can be loose, fixed to the platform or integrated to the cargo or attached to the load unit.

##### 4.2.1. Coating

A coating is most often fixed on the loading platform. The factor of friction in combination with a specific contact material of the load, should be determined as described in EN12195-1:2010.

##### 4.2.2. Rubber anti slip mats

Vulcanized rubber or agglomerated rubber can be used and different types of additives and/or reinforcements are used. Some producers add specific coloured grains. The thickness of the mats can vary between 2 and 30mm.

The factor of friction of all these types of rubber mats in combination with any other material is considered to be 0.6 in case of a clean contact surface, either dry or wet. In case of a contact surface with snow, ice, grease or oil, the friction factor is much lower as described in EN12195-1:2010. A friction factor higher than 0.6 is applicable if this is confirmed in a test certificate according to EN12195-1:2010.

There are no general rules on the minimum dimensions of rubber mats to be used. The size and thickness of the mats should be chosen to make sure that the weight of the load is fully transferred via the rubber mats, taking into account the compression of the mats under high pressure, the deformation of the load and possibly also the deformation of the loading platform. Mats smaller than 10cm by 10cm may tend to roll under a tangential force and shall not be used.

Care should be taken when using rubber mats under sharp edges. Due to high contact pressure and vibrations some types of rubber mats can be perforated, thus reducing the friction. Especially some types of rubber mats of agglomerated rubber are sensitive to this phenomenon. On the other hand, agglomerated rubber is most appropriate in dusty circumstances.

#### 4.2.3. Non rubber anti slip mats

Also non rubber materials are being used for anti -slip mats. The friction factor for these materials should be guaranteed by a test certificate according to EN12195-1:2010. Foam type materials are being used under pallet loads or between pallets and the load on the pallet. The friction factor can reach values up to 1,2 for specific material combinations in ideal circumstances. As for coatings the friction factor tends to decrease during lifetime. If these mats are very thin, it could be required to cover the entire contact surface.

#### 4.2.4 Anti slip sheets

These are paper based sheets coated with a high friction coating on silicone, PU or other basis. These sheets are most often used between layers of palletised goods but are also very suitable for transport of parcels and similar. They are available in very thin variants up to variants of thick corrugated board and should be chosen taking into account the inertia forces that tend to tear apart these sheets.

### 4.3 Blocking bars

Blocking bars are designed to be mounted in vehicles, either vertically between the loading platform and the roof, or horizontally, between both sidewalls. There is no final version of a specific international standard available for blocking bars. It is important to distinguish between the strength of a blocking bar as specified by the producer and the blocking capacity of a blocking bar. The blocking capacity strongly depends on the fixation of the blocking bar in/on the vehicle.



The fixation of most common blocking bars is friction based.



Typical blocking capacity is between 80 and 200daN.

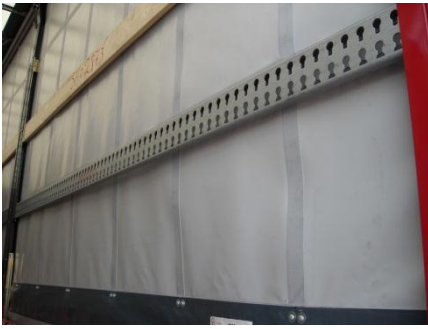

A more recent generation of blocking bars is fixed in holes in the vehicle. Since no standard dimensions for the holes are available, the blocking bars are delivered with the vehicle with a certificate mentioning the blocking capacity. Typically, this can be between 200daN and 2000daN, mainly depending on the quality of the fixation of the bars in the holes.

#### 4.4 Filler materials

Effective securing of cargo by blocking requires close stowage of the packages both against the load carrier's blocking fixtures and between the individual packages. When the cargo does not fill the space between the side and end boards, and is not otherwise secured the gaps must be filled with a filler material to create compressive forces that ensure a satisfactory blocking of the cargo. These compressive forces should be proportionate to the total cargo weight.



Some possible filler materials are shown hereafter.

- Goods pallets

Goods pallets are often a suitable form of filler material. If this clearance towards the blocking is larger than the height of a EURO pallet (about 15 cm) then the gap could be filled with, for example, such pallets standing on end, for the cargo to be properly blocked. If the clearance towards the sideboards on any side of the cargo section is smaller than the height of a EURO pallet then the gap to the sideboard must be filled with suitable filling, for example planks of wood.

- Air cushions



Inflatable air cushions are available both as disposable items and as recyclable products. The cushions are easy to install and are inflated by compressed air, often by means of an outlet in the truck's compressed air system. Suppliers of air cushions are expected to provide instructions and recommendations concerning load capacity and appropriate air pressure. For air cushions it is important to avoid damage as a result of wear and tear. Air cushions should never be used as filler against doors or any non rigid surfaces or partitions.

There are also different paper based materials on the market that can be used for stuffing, such as stuffing cardboard and crumpled cardboard (picture)

Some truck drivers use plates of isolation material such as PU plates to fill gaps.

#### 4.5 Corner protectors

There are no international standards for corner protectors. A corner protector can have one or more functions:

- Protect the lashing from being damaged by the sharp corners of the cargo
- Protect the cargo from being damaged by the lashing
- Facilitate sliding of the lashing in its longitudinal direction over the cargo
- Distribute the lashing force over a wider zone over the cargo



Some corner protectors can have a specific additional function, such as prevent the lashing from sliding in transverse direction, e.g. to keep the lashing on a cylindrical cargo edge.

Several designs of corner protectors are available on the market, with different focus on different functions and with different costs. Some types are shown in picture ...; L-shaped plastic parts are placed on the corners of the cargo and the lashing is placed on the corner protection. This is very effective

but in some cases difficult to realize. Sleeves over the lashing (often called wear protectors) are in some cases more easy to position, they are effective to protect the lashing but they do not distribute the force over a wider zone.

Some corner protectors can have a considerable length. However, they are not intended to replace the transport packaging of the cargo and cannot keep the cargo in shape (picture). Their main function is the distribution of the lashing forces over a longer zone as explained in paragraph 5.7.2.

Corner protectors should not be the cause of dangerous situations during lashing and/or transport. The use of bended steel plates as a corner protector is not acceptable since it can cause serious injuries during lashing and during transport.

The use of anti-slip mats as a corner protector is not acceptable.

## 4.6 Nets and covers



Nets used for securing or retaining certain types of cargo may be constructed from webbing straps or ropes of either natural or man-made fibres or steel wire. Webbing nets are generally used as barriers to divide the load space into compartments. Rope or cord nets may be used to secure loads either to pallets or directly to the vehicle as the primary restraint system. Their effects can be estimated by using the formulas of EN12195-1 for direct lashing or pull-down lashing according to the case.

Lighter nets can be used to cover open vehicles and skips when the type of load does not require a cover sheet. Care should be taken to ensure that the metal parts of nets are not corroded or damaged, that the webbing is not cut and that all stitching is sound. Rope and cord nets should be checked for cuts or other damages to the fibres. If necessary, repairs must be carried out by a competent person before the net is used. The mesh size of the net must be smaller than the smallest part of the cargo.

Nets can also be used to ensure that cargo cannot fall out of the vehicle when opening the doors, e.g. in case a XL coded vehicle loaded with cargo right against the back doors.

## 4.7 Other securing material

Numerous other materials are being used for cargo securing and are, in some cases, very appropriate too.

Wood is being used as dunnage material especially, in containers but also on flat-bed trailers or other vehicles for road transport. Wooden battens can be used to fill gaps between load units and between load units and rigid vehicle parts. They might be nailed on the vehicle loading platform; they can also be blocked next to rigid vehicle parts.

## Chapter 5 Securing methods

### 5.1 General principle

The basic principle of cargo securing is that movements of pieces of cargo relative to the loading platform due to accelerations of the vehicle in longitudinal and transverse directions are avoided. Only movements caused by elastic deformations of load units and securing equipment can be accepted, as long as they do not cause unacceptable high impact forces on vehicle walls or other restraining equipment. To avoid these relative movements' the following basic restraining methods can be used separately or in combination.

- locking,
- blocking ,
- direct lashing,
- top-over lashing

The restraining method(s) used should be able to withstand the varying climatic conditions (temperature, humidity...) likely to be encountered during the journey.

### 5.2 Locking

Locking is by far the best method for load securing. Vehicle and load do have a specific shape that is designed to fit together and to prevent relative movement. The strength of this design has to be checked in advance. Such a locking system should be used according to the specifications of the manufacturer.

A well-known example is the twist lock for ISO containers. The container itself is considered as cargo that is to be secured on the container trailer. 4 twist locks should be used to avoid all relative movements of the container on the trailer.

Another example is the use of steel crates for pressurized gas bottles. The feet of the crates are designed to fit in holes in the loading platform of a vehicle designed to transport these crates. A specific pin is used to lock the feet in these holes.

### 5.3 Local blocking

If the load unit to be secured is sufficiently rigid, local blocking can be used.

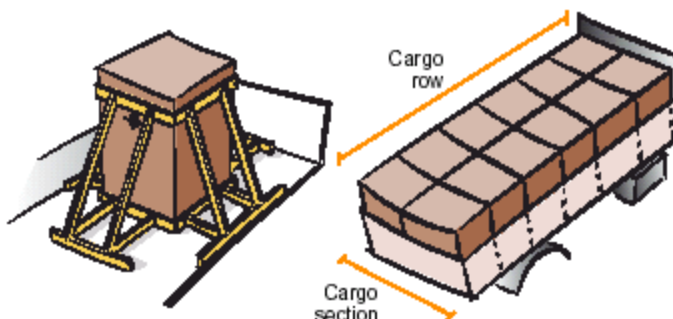

Sliding is prevented by creating rigid supports in forward, backward and each transverse direction.

- Load units are put against a rigid wall, fence or pole(s) or against another load unit.

- If a direct support against a rigid vehicle part is not possible, the gaps can be filled with pieces of wood or a similar device.

Tilting is prevented, when a load unit is tilt-sensitive, through local blocking by

creating the rigid supports at a reasonable height. To be safe without further calculation the load unit is blocked above the center of gravity. A horizontal or vertical blocking bar is often used to create this type of tilt prevention.

A specific type of local blocking is threshold blocking or panel blocking. It is often used to carry some load units on top of a lower layer. Using some type of base material, such as load pallets, the cargo section is raised so that a threshold is formed, and the upper cargo layer is locally blocked longitudinally as shown in picture... Remark that the forces in the top zone of the load unit used for blocking, can be considerably high. This concentration of forces can be reduced by placing the pallets in vertical direction between two succeeding sections.

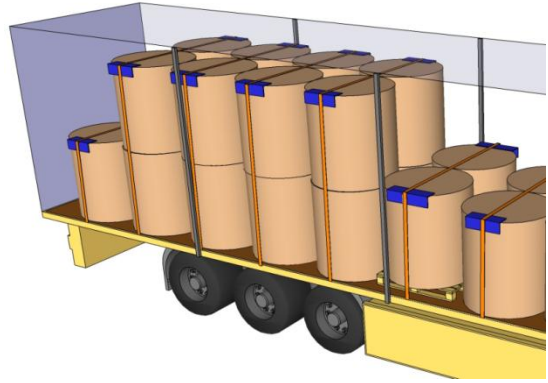

Another type of local blocking uses wedges to prevent cylindrical objects from moving along the loading platform.

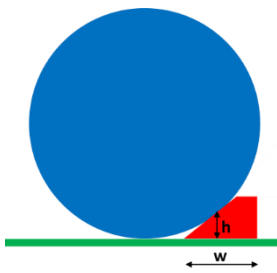

- Block wedges should have an angle of about  $37^\circ$  to prevent rolling in the forward direction and an angle about  $30^\circ$  to prevent rolling sideways or backwards. They should touch the cylindrical object on the inclined plane and should be fixed to the loading platform since the cylindrical object tends to move the wedge backwards. The horizontal force in the backward direction on the wedge is  $0.8G$  or  $0.5G$  (with  $G$  the weight of the cylinder).

The height of the wedges should be:

- minimum  $R/3$  (third of the roll radius) if there is no top-over lashing or,
  - maximum 200mm, if rolling over the wedges is preventing in other way, e.g top-over lashing.
- Pointed wedges with a  $15^\circ$  wedge angle, have a limited cargo securing capacity, and their chief function is to keep round shaped goods in position during loading and unloading. The advantage of the small angle is that the wedge normally self -locks in static conditions: it does not slide horizontal direction under the weight of the cylinder.
  - A wedge bed uses two long wedges that are kept in position by adjustable cross bracing such as bolts. The cross bracing should be arranged so that a clearance of about 20 mm is achieved between the cylinder and the loading platform. The wedges should have an angle of  $37^\circ$  for blocking in the longitudinal direction and an angle about  $30^\circ$  for blocking in the transverse direction.

## 5.4 Global blocking

In the case of global blocking, void spaces should be filled and may be favourably stuffed by empty pallets inserted vertically or horizontally and tightened by additional timber battens as necessary. Material which may deform or shrink permanently, like rags of gunny cloth or solid foam of limited strength, should not be used for this purpose. Small gaps between unit loads and similar cargo items, which cannot be avoided and which are necessary for the smooth packing and unpacking of the goods, are acceptable and need not to be filled. In case of global blocking only, the sum of void spaces in any horizontal direction should not exceed 15 cm. However, between dense and rigid cargo items, such as steel, concrete or stone, void spaces should be further minimized, as far as possible.

## 5.5 Direct lashing

Lashings are used to create a force in the opposite direction of the inertia forces. The application of this idea depends on the type of cargo.

For all variants of direct lashings, the cargo is allowed to start moving. This movement will cause an increase of the force in the lashing. This increasing force should stop the movement of the load. Since web lashings tend to strain up to 7% and since all movements of cargo should be as small as possible, the pretension in web lashings should be as high as possible, but not more than 0.5 LC. For chains, steel wire ropes and high tech



ropes the optimum pretension is not more than 0.5LC. In case of very heavy cargo units on a deformable loading platform, a detailed study of the pretension is recommended.

### 5.5.1 Diagonal lashing

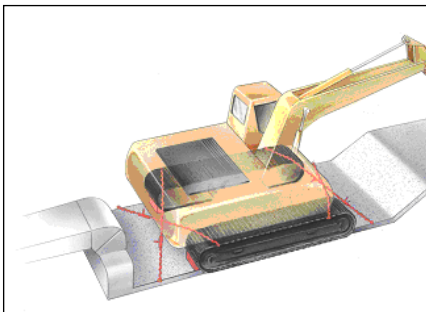

Cargo units having rigid lashing points can typically be secured by four direct lashings. Each lashing connects a lashing point on the cargo with one lashing point on the vehicle, approximately in the direction of the diagonals of the loading platform. In case of four lashings only, the lashings must not be parallel to the vertical plane in the driving direction and not parallel to the vertical plane in the transverse direction. The angles between the lashing and the horizontal plane should be as small as possible, taking into account the rigidity of the

lashing points (many lashing points shall not be used under an angle smaller than 30°). The angle between the lashing and the driving direction is preferably between 30° and 45° if diagonal lashing is not combined with blocking. Larger or smaller angles can be accepted as long as the consequent higher forces in the lashings and on the lashing points are acceptable.

If a very rigid lashing point on the cargo is available, it can be used to fix two lashings.

If suitable lashing points are missing, they can in some cases be created by using a lifting sling.

If the strength of a certain lashing or lashing point is insufficient, it should be preferably replaced by a stronger one. The use of an additional lashing may be necessary due to limited strength of lashing points or equipment. If more than two lashings are used in any direction then a safety factor shall be used to take into account an uneven distribution of forces in the lashings.

### 5.5.2 Parallel lashing

8 lashings are used to connect 8 lashing points on the vehicle with 8 lashing points on the cargo. The 8 lashings are 2 by 2 parallel and have equal lengths. 2 parallel lashings prevent movement in

forward direction, 2 parallel lashings in backward direction, 2 for left side and 2 for right side. By the use of 2 lashings for one direction, the forces in the lashings and the lashing points are smaller than in case of a diagonal lashing. In most cases a diagonal lashing is cheaper than and as effective as a parallel lashing.

### 5.5.3 Half loop lashing

Half loop lashing (sometimes called loop lashing) is most often used to prevent transverse movements of long pieces of cargo. At least 3 and preferably 4 lashings are used. Each lashing starts at a lashing point near the side of the vehicle, goes underneath the cargo and comes back over the cargo to the same lashing point or a nearby lashing point. 2 lashings in the front of the long cargo and 2 near the end are recommended. 2 lashings start at the right hand side and 2 at the left hand side. These 4 lashings have limited effect on preventing sliding of the cargo in the longitudinal direction.

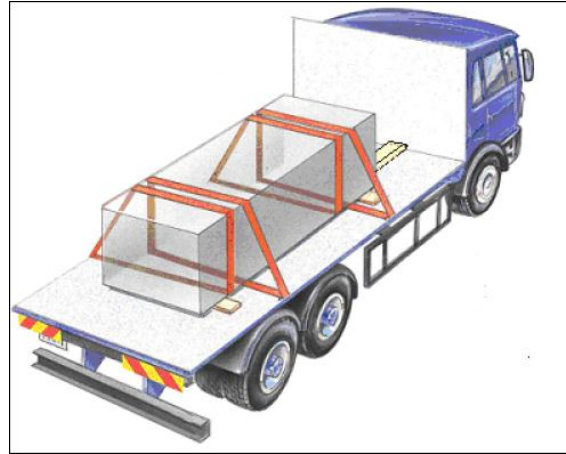

### 5.5.4 Spring lashing

Spring lashing can be used to prevent movements (sliding and tilting) in one single direction, often in the forward direction or the backward direction. One single lashing starts at a lashing point on one side of the vehicle, passes along the front (back) of the cargo and is fixed on a lashing point on the other side of the vehicle opposite or near opposite the first lashing point. Different variants of a spring lashing are used in order to avoid that the lashing would slide downwards:



- Empty pallets or similar materials are placed in front (back) of the cargo that is being secured.

- The lashing crosses the front (back) side of the cargo diagonally. This is often called cross lashing and is easy to realize by one person. For non-rigid cargo units the number of cross lashings should be high enough to avoid that parts of the cargo slide in between the lashings. An inclination test or a dynamic vehicle test can

be used to determine the effectiveness in this case.

- A sling or a specific lashing can be used on the top front (back) edge of a load section. This sling is pulled backwards (forwards) on both sides along the cargo. The effectiveness for non-rigid goods should be tested.



### 5.6 Top over lashing

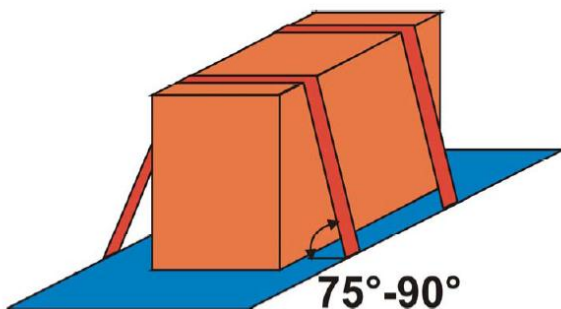

Top over lashing, also called friction lashing and pull down lashing, is used to increase the friction forces between the bottom of the loading units and the loading platform or the lower loading units in case of multiple stack loading. The angle of the lashing in the upward zones with the loading platform should be as high as possible.

An important aspect of using web lashings is the distribution of the tension forces along the lashing. In most cases the lashing is tensioned on one side using the ratchet. During the tensioning the lashing is strained and slides over the cargo. Low friction over the corner will make the distribution of lashing forces more equal on both sides. High friction over the corner will make larger difference on forces on both side, on the other hand, the lashing will act more as direct lashing.

The downward force in a top over lashing is to be generated by a tensioning device, usually operated manually. Therefore this downward force is generally limited to the STF value of the lashing equipment. The LC value is irrelevant for top over lashing.

The force in a top over lashing over deformable products changes during transport. In almost all cases this change is a significant decrease, down to 50% of the original pretension or even less. Therefore, retightening of lashing during the journey should be considered or another securing method should be used. For non-deformable cargo the tension force does normally not change and in some specific cases the tension force can also increase.

The downward force contributes to the cargo securing as far as it increases the friction force. As explained in chapter 1, the friction force is only a portion of the contact force. The contact force is the total downward force in the lashings plus the weight of the cargo on this contact surface. This means that top over lashing is most efficient with high friction factor.

## 5.7 General remarks on securing methods

1. All load units should be secured. In some cases it is recommended to group a number of load units and to secure the group as a whole. It is very likely that a group of load units as a whole is not tilt sensitive, even if the individual load units are. In that case, the group should only be secured against sliding. Grouping can be done by horizontal or vertical round lashing (picture). By way of example, 4 long load units are grouped by 3 vertical round lashings. The tension in the lashing should be as high as possible, thus creating friction forces between the individual load units. The effect of round lashing and the maximum number of load units in one round lashing depends on the tensioning force and on the coefficient of friction. It is assumed that 4 pallet loads on a trailer can be grouped by one horizontal round lashing, and that 4 long load units can be grouped by 3 vertical group lashings. The effectiveness of grouping of load units should be tested case by case.
2. The contact force between a web lashings and the cargo can increase considerably at the moment the inertia forces effectively occur, both for direct lashing and top over lashing. In case of deformable cargo, these high local forces will cause a deformation of the cargo and thus free space for the cargo to move, comparable to the movement of the cargo due to the elongation of a strap. This is the main reason, apart from avoiding product damage, that high local contact forces on the cargo shall be avoided. The use of large corner protectors can contribute to the distribution of lashing forces over a greater zone and thus to the reduction of the movement of the cargo.
3. Different lashing methods can be combined. One exception: locking requires specific locking devices on the vehicle and the cargo. The stiffness of a locking device is most often not compatible with other securing methods. Therefore, locking equipment should be strong enough so that other securing is redundant. The combination of blocking and top over lashing is described in EN12195-1:2010. The blocking capacity and the securing capacity of the lashing can be added.
- 4 Interesting example of combined lashing method is the cross over lashing which is a combination of top over lashing and spring lashing.
- 5 Larger pieces of non-palletized cargo is often loaded on wooden battens. Even in case of a severe pull down lashing and in case of direct lashing, such battens may tend to roll at the moment the inertia forces effectively occur. This rolling shall be avoided by either:
  - Use rectangular battens in the horizontal direction (height of battens horizontal)
  - Use equal thick battens under an angle that is more than 30°
6. Friction factors of material combination not mentioned in the table B.1 of standard EN 12195-1:2010, can be determined by a test documented according to Annexes B and E of this standard.
7. In cases where global blocking is used in a vehicle with sufficient superstructure strength such as an XL coded vehicle no further securing such as lashing is required. Vehicle walls should be used with care if the forces from the cargo are not uniformly spread out over the sides.
8. Stacking of cargo is possible, however different friction factors, strength of packaging as well as specific requirements for dangerous goods have to be taken into account.

## Chapter 6 Calculations

Appendix 3 provides a quick lashing guide with simplified methods that can be used to decide on required number of lashings. It is recommended to secure the cargo as usual and then check by the help of the tables in the quick lashing guide if the applied securing arrangement is sufficient to prevent sliding and tipping of the cargo in all directions.

In many cases calculations can be avoided. For example, in case of blocking the cargo in all directions in an XL coded vehicle and equipped as per certificate, no further securing is required if the friction factor between the loading platform and the cargo is 0.3 or higher, even for a full truck load.

If calculations are necessary, they should be done in accordance with the standard EN 12195-1:2010.

Alternatively cargo securing arrangements can be tested in accordance with the instructions in the standard EN 12195-1:2010.

In case two or more securing methods are combined, the formulas described in the standard EN 12195-1:2010 may be used in combination for calculation as described in the examples below.

### 6.1 Example 1 - wooden crate with low centre of gravity

Calculate the maximum allowed weight of the wooden box, considered as rigid, loaded on a trailer according to the figure below by the help of the formulas in the standard EN 12195-1:2010 to avoid sliding and tipping sideways, forward and backward.

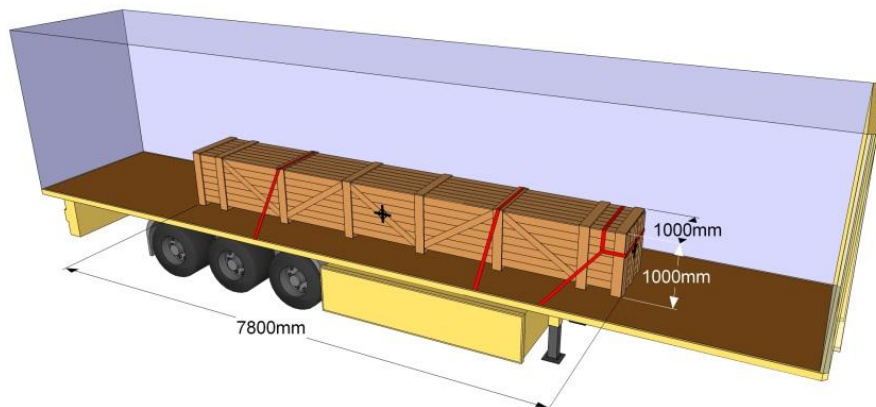

The trailer has an ordinary plywood floor that is swept clean and is free from frost, ice and snow. The trailer is built according to the standard EN 12642, class XL and the lashing points on the trailer are designed according to the standard EN 12640, each with an LC of 2000 daN. The transverse distance between the lashing points is about 2.4 m.

The box is made of sawn wood and it has the following dimensions; length x breath x height = 7.8 x 1.0 x 1.0 m. The center of gravity is located in the geometrical center of the box.

The box is secured by two top-over lashings and one spring lashing applied in forward direction. The lashings have an LC of 2000 daN and are pre-tensioned to 500 daN. The spring lashing is fixed to the trailer about 1 m behind the forward part of the box and the lashings thus have the following approximate angles:

The top-over lashings; Vertical lashing angle between the lashings and the platform  $\alpha \approx 55^\circ$

Spring lashing: Vertical lashing angle between the lashing and the platform  $\alpha \approx 39^\circ$  and the horizontal angle between the lashing and the longitudinal axle of the vehicle  $\beta \approx 35^\circ$

### 6.1.1 Sliding

The friction factor  $\mu$  between the box of sawn wood and the plyfa floor of the trailer is 0.45 according to annex B of the standard.

### 6.1.2 Cargo with mass m prevented from sliding by the two top-over lashings

The cargo mass m prevented from sliding by the two top-over lashings is based on equation 10 of the standard.

$$m = \frac{n \cdot 2 \cdot \mu \cdot \sin \alpha \cdot F_T}{g(c_{x,y} - \mu \cdot c_z) f_s}, \text{ where:}$$

m = the cargo mass. The mass is obtained in kg if  $F_T$  is given in Newton (N) and in ton if  $F_T$  is given in kiloNewton (kN). 1 daN = 10 N and 0.01 kN.

n = 2; number of top-over lashings

$\mu$  = 0.45; friction factor

$\alpha$  =  $55^\circ$ ; vertical lashing angle in degrees

$F_T$  = 500 daN = 5 kN

g = 9.81 m/s<sup>2</sup>, the gravity acceleration

$c_{x,y}$  = 0.5 sideways, 0.8 forward and 0.5 backward; the horizontal acceleration coefficient

$c_z$  = 1.0; the vertical acceleration coefficient

$f_s$  = 1.25 forward and 1.1 sideways and backward; safety factor

By these values the cargo mass m in ton prevented from sliding in the different directions by the two top over lashings is:

Sideways: 13.7 ton

Forward: 1.7 ton

Backward: 13.7 ton

### 6.1.3 Cargo mass prevented from sliding forward by the spring lashing

The cargo mass m prevented from sliding in forward direction by the spring lashing is based on equation 35 of the standard. The influence of the spring lashing to prevent transverse sliding is neglected.

$$m = \frac{2 \cdot n \cdot F_R \cdot (\mu \cdot f_\mu \cdot \sin \alpha + \cos \alpha \cdot \cos \beta)}{g \cdot (c_x - \mu \cdot f_\mu \cdot c_z)}, \text{ where}$$

$m$  = the cargo weight. The weight is obtained in kg if  $F_T$  is given in Newton (N) and in ton if  $F_T$  is given in kiloNewton (kN). 1 daN = 10 N and 0.01 kN.

$n = 1$ ; number of spring lashings

$F_R = LC = 2000$  daN = 20 kN

$\mu = 0.45$ ; friction factor

$f_\mu = 0.75$ ; safety factor

$\alpha = 39^\circ$ ; vertical lashing angle in degrees

$\beta = 35^\circ$ ; horizontal lashing angle in degrees

$g = 9.81$  m/s<sup>2</sup>, the gravity acceleration

$c_x = 0.8$ ; the horizontal acceleration coefficient in forward direction

$c_z = 1.0$ ; the vertical acceleration coefficient

By these values the cargo mass  $m$  in ton prevented from sliding in forward direction by the spring lashing is 7.5 ton.

### 6.1.4 Cargo weight prevented from sliding by the two top-over lashings and the spring lashing

The above calculations give that the two top-over lashings and the spring lashing can prevent the following cargo weight from sliding:

Sideways: 13.7 ton

Forward: 1.7 + 7.5 = 9.2 ton

Backward: 13.7 ton

The maximum cargo weight prevented from sliding by the actual securing arrangement is thus 9.2 ton.

### 6.1.5 Tipping

The stability of the box is checked by equation 3 of the standard.

$b_{x,y} > \frac{c_{x,y}}{c_z} d$ , where:

$b_{x,y} = 0.5$  sideways, 3.9 forward and 3.9 backward; the horizontal distance from the center of gravity and the tipping point in each direction

$c_{x,y} = 0.5$  sideways, 0.8 forward and 0.5 backward; the horizontal acceleration coefficient

$c_z = 1.0$ ; the vertical acceleration coefficient

$d = 0.5$ ; the vertical distance from the center of gravity to the tipping point

By these values it can be concluded that the box is stable in all directions and no lashing is required to prevent tipping.

## 6.1.6 Conclusion

The maximum allowed cargo weight of the box secured by two top-over lashings and one spring lashing is thus 9.2 ton to prevent sliding and tipping in all directions.

## 6.2 Example 2 - wooden crate with high centre of gravity

Calculate the maximum allowed weight of the wooden box loaded on a trailer according to the figure below by the help of the formulas in the standard EN 12195-1:2010 to avoid sliding and tipping sideways, forward and backward.

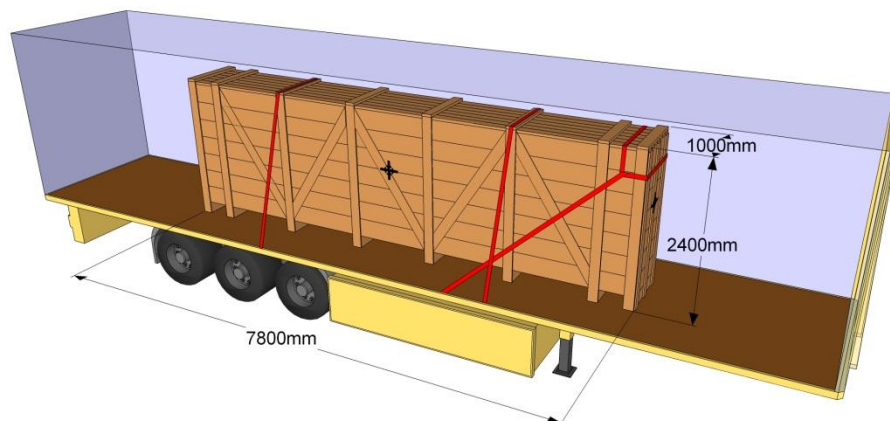

The trailer has an ordinary plyfa floor that is swept clean and is free from frost, ice and snow. The trailer is built according to the standard EN 12642, class XL and the lashing points on the trailer are designed according to the standard EN 12640, each with an LC of 2000 daN. The transverse distance between the lashing points is about 2.4 m.

The wooden box is made of sawn wood and it has the following dimensions; length x breath x height = 7.8 x 1.0 x 2.4 m. The center of gravity is located in the geometrical center of the box.

The box is secured by two top-over lashings and one spring lashing applied in forward direction. The lashings have an LC of 2000 daN and are pre-tensioned to 500 daN. The spring lashing is fixed to the trailer about 2.5 m behind the forward part of the box and the lashings thus have the following approximate angles:

The top-over lashings; Vertical lashing angle between the lashings and the platform  $\alpha \approx 74^\circ$

Spring lashing: Vertical lashing angle between the lashing and the platform  $\alpha \approx 43^\circ$  and the the horizontal angle between the lashing and the longitudinal axle of the vehicle  $\beta \approx 16^\circ$

### 6.2.1 Sliding

The friction factor  $\mu$  between the box of sawn wood and the plyfa floor of the trailer is 0.45 according to annex B of the standard.

## 6.2.2 Cargo weight prevented from sliding by the two top-over lashings

The cargo weight  $m$  prevented from sliding by the two top-over lashings is based on equation 10 of the standard.

$$m = \frac{n \cdot 2 \cdot \mu \cdot \sin \alpha \cdot F_T}{g(c_{x,y} - \mu \cdot c_z) f_s}, \text{ where:}$$

$m$  = the cargo weight. The weight is obtained in kg if  $F_T$  is given in Newton (N) and in ton if  $F_T$  is given in kiloNewton (kN). 1 daN = 10 N and 0.01 kN.

$n = 2$ ; number of top-over lashings

$\mu = 0.45$ ; friction factor

$\alpha = 74^\circ$ ; vertical lashing angle in degrees

$F_T = 500$  daN = 5 kN

$g = 9.81$  m/s<sup>2</sup>, the gravity acceleration

$c_{x,y} = 0.5$  sideways, 0.8 forward and 0.5 backward; the horizontal acceleration coefficient

$c_z = 1.0$ ; the vertical acceleration coefficient

$f_s = 1.25$  forward and 1.1 sideways and backward; safety factor

By these values the cargo weight  $m$  in ton prevented from sliding in the different directions by the two top over lashings is:

Sideways: 16.0 ton

Forward: 2.0 ton

Backward: 16.0 ton

## 6.2.3 Cargo weight prevented from sliding forward by the spring lashing

The cargo weight  $m$  prevented from sliding in forward direction by the spring lashing is based on equation 35 of the standard. The influence of the spring lashing to prevent transverse sliding is neglected.

$$m = \frac{2 \cdot n \cdot F_R \cdot (\mu \cdot f_\mu \cdot \sin \alpha + \cos \alpha \cdot \cos \beta)}{g \cdot (c_x - \mu \cdot f_\mu \cdot c_z)}, \text{ where}$$

$m$  = the cargo weight. The weight is obtained in kg if  $F_T$  is given in Newton (N) and in ton if  $F_T$  is given in kiloNewton (kN). 1 daN = 10 N and 0.01 kN.

$n = 1$ ; number of spring lashings

$F_R = LC = 2000$  daN = 20 kN

$\mu = 0.45$ ; friction factor

$f_\mu = 0.75$ ; safety factor

$\alpha = 43^\circ$ ; vertical lashing angle in degrees

$\beta = 16^\circ$ ; horizontal lashing angle in degrees

$g = 9.81$  m/s<sup>2</sup>, the gravity acceleration

$c_x = 0.8$ ; the horizontal acceleration coefficient in forward direction

$c_z = 1.0$ ; the vertical acceleration coefficient

By these values the cargo weight  $m$  in ton prevented from sliding in forward direction by the spring lashing is 8.2 ton.

#### 6.2.4 Cargo weight prevented from sliding by the two top-over lashings and the spring lashing

The above calculations give that the two top-over lashings and the spring lashing can prevent the following cargo weight from sliding:

Sideways: 16.0 ton

Forward:  $2.0 + 8.2 = 10.2$  ton

Backward: 16.0 ton

The maximum cargo weight prevented from sliding by the actual securing arrangement is thus 10.2 ton.

#### 6.2.5 Tipping

The stability of the box is checked by equation 3 of the standard.

$$b_{x,y} > \frac{c_{x,y}}{c_z} d, \text{ where:}$$

$b_{x,y} = 0.5$  m sideways, 3.9 m forward and 3.9 m backward; the horizontal distance from the center of gravity and the tipping point in each direction

$c_{x,y} = 0.5$  sideways, 0.8 forward and 0.5 backward; the horizontal acceleration coefficient

$c_z = 1.0$ ; the vertical acceleration coefficient

$d = 1.2$  m; the vertical distance from the center of gravity to the tipping point

By these values it can be concluded that the box is stable in forward and backward direction but not sideways.

#### 6.2.6 Cargo weight prevented from tipping sideways by the two top-over lashings

The effect of the spring lashing preventing sideways tipping is neglected and the cargo weight  $m$  prevented from tipping by the two top-over lashings is based on equation 16 of the standard. For one row and the center of gravity located in the geometrical center, the cargo weight can be calculated by the following formula:

$$m = \frac{2 \cdot n \cdot F_T \cdot \sin \alpha}{g \cdot (c_y \cdot \frac{h}{w} - c_z) \cdot f_s} \text{ where:}$$

$m$  = the cargo weight. The weight is obtained in kg if  $F_T$  is given in Newton (N) and in ton if  $F_T$  is given in kiloNewton (kN). 1 daN = 10 N and 0.01 kN.

$n = 2$ ; number of top-over lashings

$F_T = S_{TF} = 500 \text{ daN} = 5 \text{ kN}$  or  $= 0.5 \times LC = 1000 \text{ daN} = 10 \text{ kN}$

$\alpha = 74^\circ$ ; vertical lashing angle in degrees

$g = 9.81 \text{ m/s}^2$ , the gravity acceleration

$c_y = 0.5$  calculated with  $F_T = S_{TF}$  or  $0.6$  calculated with  $F_T = 0.5 \times LC$ ; the sideways horizontal acceleration coefficient

$h = 2.4 \text{ m}$ ; the height of the box

$w = 1.0 \text{ m}$ ; the width of the box

$c_z = 1.0$ ; the vertical acceleration coefficient

$f_s = 1.1$ ; safety factor sideways

By these values the cargo weight  $m$  in ton prevented from tipping sideways is the lowest of 8.9 and 8.1 ton. Thus the two top-over lashings can prevent 8.1 ton from tipping sideways.

### 6.2.7 Conclusion

The maximum allowed cargo weight of the box secured by two top-over lashings and one spring lashing is thus 8.1 ton to prevent sliding and tipping in all directions.

### 6.3 Example 3 - Palletized consumer goods

Many palletized goods, for instance consumer goods, are loaded from the rear of a vehicle with forklift trucks or stand-on riders. If the packaging is not rigid and deforms if a force is applied lashings cannot be used to secure the load.

If the total mass of the cargo stays below a certain value, the confines of the vehicle (e.g. rigid walls, tarpaulin) will be sufficient to ensure the load cannot move, supposed the following conditions are in place.

- Each pallet load is a uniform block. Gaps caused by pallet underhang must be closed with void fillers. Over the width of the vehicle the total void shall not exceed 15 cm.
- The quality of the transport packaging ensures that the pallet load withstands an acceleration of 0.5g in all directions of travel and individual consumer units cannot break through the stretch film.



The maximum permissible total mass of the load without further load securing arrangements can be calculated with help of a force balance.

## Force balance

There are three main forces acting on a stack of two pallets:

1. Acceleration force  $F_A$  in longitudinal and transverse directions.
2. Frictional force  $F_F$  between the bottom pallet and the truck floor as well as between the bottom and top pallet
3. Global blocking force  $F_B$  of the vehicle walls (rigid walls, tarpaulin)

The acceleration force  $F_A$  acting on the center of gravity of top and bottom pallet is  $F_A$ .

$$F_A = m_p * a \quad m_p: \text{pallet mass, } a: \text{acceleration (either } 0.5g \text{ or } 0.8g \text{ and } g = 9.81 \text{ m/s}^2)$$

The frictional force can be calculated as fraction of the gravitational force of the load perpendicular to the truck floor with the friction factor  $\mu$  taken from EN 12195-1.

$$F_F = \mu * m * g \quad \mu: \text{friction factor, } m: \text{mass of the load, } g=9.81 \text{ m/s}^2$$

The global blocking force of the vehicle confines (rigid walls, tarpaulin) depends on the vehicle type and body construction and is a function of the vehicle payload  $P$ . EN 12642 provides guidance for code L and code XL trucks and the three main body structures curtainsiders, drop site body, box type body. EN 283 can be used to derive the restraining forces for swap bodies.

$$F_B = s * P * g \quad s: \text{static test requirement according to EN 12642, } P : \text{payload in kg, } g=9.81 \text{ m/s}^2$$

To calculate the maximum permissible cargo mass  $m_t$  without additional measures for load security the sum of accelerating force, frictional force and restraining force must be zero. If the sum of all forces is zero, the load does not move.  $F_F$  and  $F_B$  are negative because they act opposite to the direction of the accelerating force.

$$F_A - F_F - F_B = m_t * a - \mu * m_t * g - s * p * g = m_t * (a - \mu g) - s * p * g = 0$$

Above equation can be resolved for the total cargo mass  $m_t$  and yields:

$$m_t = (s * p * g) / (a - \mu g)$$

The maximum permissible mass of the cargo must be calculated in forward, backward and sideward directions. The lowest value for  $m_t$  denotes the safe total mass that can be transported without additional measures for load security.

To calculate the maximum permissible pallet mass  $m_p$  in case all pallets have the same mass, the value  $m_t$  must be divided by the number of pallets spots  $N$  on the truck. This approach also accounts for an even distribution of forces across the truck confines as required by EN 12642. This yields the following equation:

$$m_p = (s * p * g) / ((a - \mu g) * N * k) \quad N: \text{Number of pallet spots in the truck/trailer/swap body} \\ k: \text{number of pallet layers in the calculation}$$

To calculate the maximum mass of a stack of pallets (i.e. two pallets on top of each other) the calculation must be done twice, once for the top layer (with  $s$  according to the upper part of the vehicle and  $\mu$  as friction factor between top on bottom pallet) and once for the stack of pallets (with  $s$  for the complete wall and  $\mu$  as friction factor between bottom pallet and truck floor).

## Chapter 7 Check of cargo securing

Checking of cargo securing shall be performed in accordance with Article 13 and Annex V of Directive 2014/47/EU on technical roadside inspections of commercial vehicles circulation in the Union.

The goal of an inspection is to check if the applied load securing system will resist the inertia forces as mentioned in Article 13 of Directive 2014/47/EU.

Any inspection should always be based on the principles of the EN 12195-1 and these guidelines.

For the inspection, the cargo and the cargo securing system should be visible. Authorized inspectors may remove seals. The driver should open the vehicle or remove a cover when present. If necessary an inspector should enter the vehicle to be able to see the applied load securing system. The driver should provide all other information that is required and might help to judge on the effectiveness of the cargo securing system such as certificates on vehicle's strength, load securing protocols, test reports or load distribution diagrams.

An inspector is not supposed to propose the necessary improvements in order to meet the requirements of the cargo securing system. In many cases a solution is even impossible without reloading the entire load on the same or another vehicle, without additional load securing equipment, without better product packaging,

### 7.1 Classification of deficiencies

Deficiencies shall be classified into one of the deficiency groups:

- Minor deficiency: A minor deficiency exists when the load has been properly secured but a safety advice might be appropriate.
- Major deficiency: A major deficiency exists when the load has not been sufficiently secured and a significant shifting or overturning of the load or parts thereof is possible.
- Dangerous deficiency: A dangerous deficiency exists when traffic safety is directly endangered due to a risk of loss of cargo or parts thereof or a hazard deriving directly from the cargo or an immediate endangering of persons

When several deficiencies are present, the transport is classified in accordance with the highest deficiency group. If, in the event that there are several deficiencies, as the effects based on the combination of these deficiencies are expected to reinforce one another, the transport shall be classified in the next higher deficiency level.

### 7.2. Methods of inspection

The method of inspection is a visual assessment of the proper use of appropriate measures in necessary amount to secure cargo and/or measurement of tension forces, calculation of securing efficiency and checking of certificates where appropriate.

The inspector should use a holistic approach when checking the securing of cargo taking into account all elements that could be of relevance. These elements include the vehicle and its suitability for the transported cargo, the strength and condition of parts used for the securing, the method or combination of methods applied and the securing devices used.

### 7.3. Assessment of deficiencies

The table in Annex 4 provides rules that may be applied during a cargo securing inspection to determine whether the condition of the transport is acceptable.

The categorisation of the deficiencies shall be determined on the basis of the classifications as described in chapter 7.1, on a case by case basis.

Values stated in the table below are of an indicative nature and should be considered as a guideline to determine the category of deficiency in light of the specific circumstances - in particular depending on the nature of the cargo - and upon the discretion of the inspector.

In case of a transport falling within the scope of Directive 95/50/EC<sup>4</sup> on uniform procedures for checks on the transport of dangerous goods by road, more specific requirements may apply.

---

<sup>4</sup> OJ L 249, 17.10.1995, p. 35.

## Chapter 8 Examples of cargo securing arrangements for specific goods

In this chapter some cargo securing methods for specific goods that cannot easily be designed by simple application of the principles mentioned above, are described.

### 8.1 Panels stowed on flat platform with A-frames.

A-frames are very often used to transport large flat objects such as glass plates, concrete walls, thick steel plates, etc.

The A-frames can be permanently fixed on the vehicle or can be removable and the A-frames can be oriented in the driving direction or in the transverse direction.

In all these cases the strength of the A-frame is a major concern.

An A-frame may tend to bend or break under the inertia forces on the panels. Removable A-frames can also bend or break when lifted up. A-frames should thus be professionally designed and it is recommended that a certificate is issued stating the maximum allowed weight of the cargo to be transported in the frame, the maximum height of the cargo on the frame, the method to secure the cargo to the frame and if applicable the method to secure the frame to the vehicle. The certificate should be signed by the designer or the responsible person.



In case of removable A-frames the securing arrangements have to prevent sliding and tilting of the A-frame loaded with the panels. Locking is the recommended method. If locking is not applicable, local blocking should be used to prevent sliding. Often direct lashing is applicable to prevent tilting. Remark that a direct lashing starting from the top of the A-frame to the vehicle structure, does often not prevent the frame to slide.

A-frames shall be loaded and unloaded symmetrically: approximately the same weight on both sides of the frame. If properly designed and used, an A-frame is a very reliable construction to support large panels during transport. In practice A-frames have a high risk rating due to improper use. Appropriate training is strongly recommended.

It is strongly recommended that the foot of the A-frame is in straight angle (or smaller) towards the sloping side according to the figure below. If this is not possible the cargo should be placed on wedges fixed to the platform.

In all these cases the cargo has to be secured properly on the A-frame. Basically the methods explained in chapter 5 are applicable.

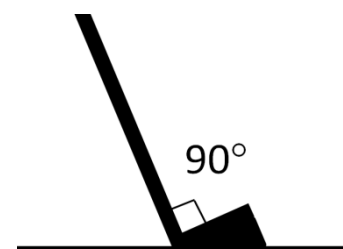

- Local blocking by means of a mechanical stop is the preferred method to avoid sliding of the panels in the plane of the panels. This method is easy to apply for A-frames that are designed for specific types and dimensions of the panels. Alternatively low horizontal spring lashings are used.
- To avoid tilting of the panels two or more round lashings - with proper protection of the lashings on sharp corners - can be used. The minimum number of lashings to prevent tilting depends on the slope angle of the A-frame, on the thickness of the panels, on the inclination angle of the foot of the frame, on the friction between panels, on the elasticity of the lashings, ...
- Alternatively top-over lashings can be used to prevent sliding and tipping in transverse direction. The minimum number of lashings that are required has to be calculated using the formulas as mentioned in the EN12195-1. Bottom blocking could be used to prevent sliding in transverse direction.
- The use of anti-slip mats or wood in the contact zone between the cargo and the A-frame is recommended.



Picture X

## 8.2 Timber loads

This section provides general guidance on measures for the safe carriage of timber, both round and sawn timber. Timber is a 'live' commodity, which can lead to independent movement of parts of the load if the restraint is inadequate.

### 8.2.1 Sawn Packaged Timber

Sawn timber is usually transported in standard packages complying with ISO4472 and related standards. If wood is covered, e.g. by shrink film or winding film, different values for friction have to be applied. The packages are generally strapped or wired and before loading the straps should be checked for safety. If the straps are damaged or insecure extra care must be taken to ensure that the complete load is adequately secured to the vehicle. However, steel or plastic straps must not be considered as cargo securing.

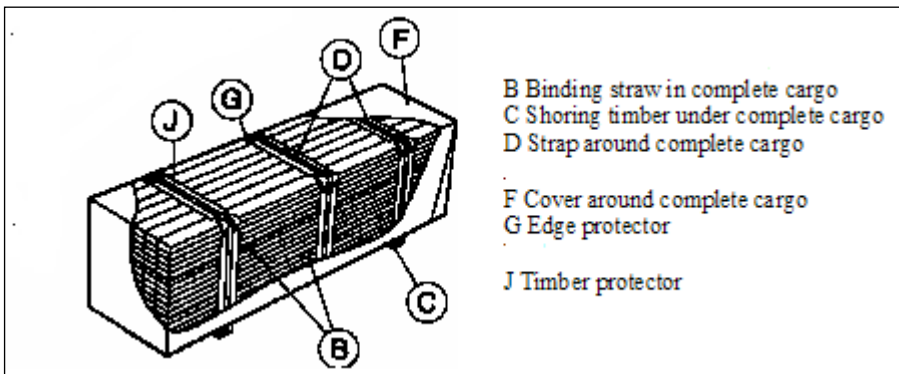

### *Standardised package in accordance with ISO 4472*

Packages of sawn timber should preferably be transported on loading platforms equipped with centre stanchions. Where centre stanchions are used each section should be secured for sideways movement by:

- At least two stanchions if the length of the section is 3.3 m or below
- At least three stanchions if the length of the section is above 3.3 m

In addition to the centre stanchions each section should be secured by at least three top over lashings with a pretension of at least 400 daN and an LC of at least 1600 daN each.

In longitudinal direction the packages should be secured as any type of cargo.

If centre stanchions are not available and where the packages are properly and rigidly bundled, the packages can be secured as any type of cargo.

### **8.2.2 Round Timber and non-packaged Sawn Timber**

The general principles of load distribution should be adhered to, and it is important to ensure that, whenever possible, the load is blocked against the headboard.

The use of chain or web lashings with tensioner is recommended and all lashings should be checked and kept tight during the whole transport operation. All lashings shall have an LC of at least 1600 daN with a pretension of at least 400 daN. It is recommended to use self-tensioning tensioner.

The load and lashings should especially be checked before passing from a forest road to public highway.

The transporting of timber stacked transversely (lying across the vehicle) supported by the front headboard and the rear support (bolster) is not recommended, it is safer to transport it longitudinally (lying along the length of the vehicle) in several sections, each individually supported by upright supports (stanchions).

#### Stacked Longitudinally

Each outer log or piece of timber shall be restrained by at least two pairs of upright supports (stanchions). The strength of the stanchions shall be sufficient to prevent the vehicle from being over width after having been exposed to a side acceleration of 0.5 g. Any timber that is shorter

than the distance between two stanchions should be placed in the centre of the load and all logs should preferably be laid top to tail alternately to ensure an evenly balanced load. The ends of the timber should extend at least 300 mm beyond the stanchions.

### *Transport of round wood*

The centre of either top of the outside timbers must be no higher than the stanchions. The top of the middle timbers must be higher than the side timbers to 'crown' the load and enable it to be properly tensioned by the lashings, as illustrated below:

The trees shall rest on a taper gib or toothed lath.

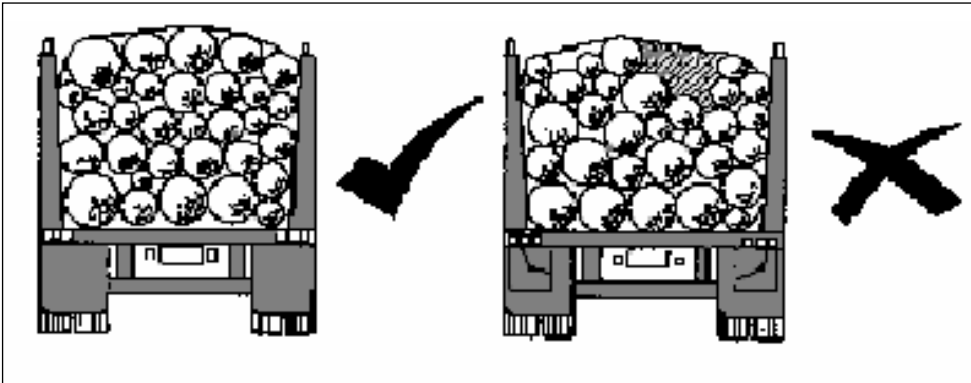

*Correct (left) and incorrect (right) loading of round timber*

### Vehicle combination with headboard on towing vehicle

In front of the first section of timber- between the drivers cab and the timber – a headboard should be fitted with strength in accordance with standard EN12642 class XL and the load should be no higher than the headboard.

Top-over lashings or similar creating a vertical pressure on the timber should be tightened over each cargo section (timber pile) in the following numbers:

- a) At least one lashing if the cargo section consists of timber with bark still present, up to a maximum length of 3.3 m;
- b) At least two lashings if the cargo section is longer than 3.3 m or irrespective of the length if the bark has been removed.



The top-over lashings should be placed (transversely) between each cargo section's front and rear pairs of side stanchions as symmetrically as possible.

### Vehicle combination without headboard on towing vehicle

If a vehicle is not fitted with a headboard of sufficient strength or automatic pretensioners, more lashings are needed, i.e. 2 lashings up to a length of the timber of 3 m, 3 lashings up to 5 m and 4 lashings from 5 m up.

Note: If the timber is not free of snow and/or ice, additional lashing is required according to the remaining friction.

### Stacked transversely

Timber stacked transversely across a flat-bed vehicle cannot be adequately secured by conventional restraining methods. Experiments have shown that timber stacked transversally in an emergency braking behave similar to a liquid load. Passing straps or chains from the front of the vehicle across the top of the timber to the rear with cross straps is not an acceptable load securing method.

Timber stacked transversally shall be carried only between rigid sidewall or cage walls, where for the latter, no piece of wood shall fit through the aperture of the cage. In longitudinal direction, the load has to be subdivided into sections with rigid bulkheads or stanchions. No section shall be longer than 2,55 m. Each section shall be top-over-lashed by at least two lashings with a pretention force of at least 400 daN and an LC of at least 1600 daN each.

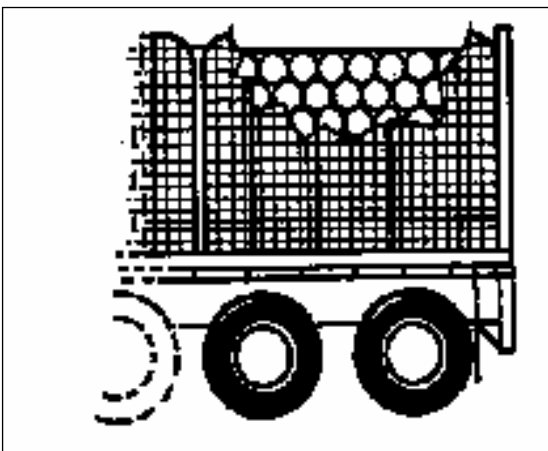

*Timber stacked transversely with side gate*

### 8.2.3 Long poles

The carriage of long poles and whole trees is a very specialised field of timber haulage. The particular problem of length can be solved by either using conventional semitrailers with long overhang. In principle, the same rules would apply as for standard length timber transport, taking the additional length into account for calculation of the number of lashings and their strength. However,



in most cases this solution does not suit the extreme length of trees.

Hence, trees are loaded on two revolving chassis with one pair of stanchions each. The typical case is the use of a dolly, which is linked to the towing vehicle only by the load. Normally, these dollies have a steering axle, which is mechanically or hydraulically controlled by the angle between load and dolly. The dolly is towed by the towing vehicle via the load, but it has its own brakes.



Particularly for emergency braking, perfect coordination between the towing vehicle's brakes and the brakes of the dolly is required in order to avoid high forces being transmitted from the dolly via the load to the towing vehicle. Therefore, appropriate maintenance is very important for this kind of vehicle.

The load shall be secured with at least two lashings per pair of stanchions in order to back-up a failure of one the lashings. Each single lashing should have a pretension force of at least  $s_{ff} =$

750 daN. At each pair of stanchions, the front one and the rear one, pretension forces of at least 2000 daN shall be applied.

In many countries, this kind of transport requires a specific permit as an abnormal transport event. Many additional measures may be required, such as additional lighting, flash lights or even an escort.

### 8.3 Large containers

ISO-containers and similar load carriers with anchorage points for twist locks should preferably be transported on loading platforms with suitable twist locks applied. However large containers for road transport, with or without cargo, can alternatively be secured with a single method or a combination of methods as described in chapter 5 and calculated as described in chapter 6.

### 8.4 Transport of mobile machinery

The following section provides guidance on the measures necessary for the safe carriage of "mobile working machines" on tracks or wheels; such as cranes, bulldozers, rollers, scrapers, forklift trucks, scissor lifts or cherry pickers, on vehicles allowed unrestricted circulation within the EU. It does not deal with the carriage of large machines etc. on special purpose vehicles whose use on the roads is restricted by permits. However, the general advice contained in this section will apply in many cases.

It is strongly recommended that manufacturers of such machinery provide comprehensive instructions on how to secure their products for transport, the required securing equipment and advice on proper stowing and securing. Further, manufacturers shall fit lashing points if needed and properly mark them. For machinery equipped with lashing points dedicated for transport use, these points shall be used and the machinery stowed and secured according to the manufacturer's instructions. In the event of the manufacturer's recommendations being unavailable, lashings or securing devices should only be attached to those parts of the machinery which are of sufficient strength to withstand the stresses likely to be imposed on them. E.g., crawler chains shall not be used to attach hooks of web or chain lashings unless this is authorised by the manufacturer.

Drivers shall particularly consider the typical dangers of these kind of transport events:

- Drivers shall check the dimensions of the transport before departure and check the route for potential obstacles, such as bridges with low clearance. Additionally, the actual height of vehicle plus load may be indicated in the cabin as a reminder to the driver.
- Loads with a high centre of gravity can seriously affect the vehicle's stability and such machinery should only be transported on vehicles with a low platform height.

A wheeled or tracked machinery must be lashed on the carrying vehicle with the parking brake applied. The effectiveness of the parking brake on its own will be limited by the frictional resistance between the machinery and the deck of the carrying vehicle as well as by the breaking capacity of the parking break. Even in normal driving conditions this will be inadequate and the vehicle will therefore require additional restraint. This additional restraint should take the form of a lashing system and/or some arrangement whereby the load is prevented from moving either forward or to the rear by a blocking device securely fixed to the vehicle. These should butt against the wheels or tracks or some other part of the equipment carried.

All moveable assemblies such as jibs, brackets, booms and cabs etc. must be left in the position recommended for transportation by the manufacturer and must be secured to prevent movement relative to the main body of the machine.

Before the machine is moved onto the transport vehicle, all loose dirt that may otherwise come off and obstruct the road or damage other vehicles, must be removed. The ramp, the tyres of the machine and the bed of the transport vehicle itself shall all be free from oil, grease, ice etc. for not to lower friction between load and platform.

The machine should preferably be positioned on the carrying vehicle's platform so that forward movement is blocked by part of the main body of the vehicle, e.g. swan neck, step or headboard, or by an attached transverse member securely attached through the platform to the vehicle's chassis frame. Additionally, the machinery and any of its detached assemblies should be arranged so that the legal axle weight limits are not exceeded and the safe handling of the vehicle is not impaired. The clearance between the undersides of low loading vehicles and the road surface should be checked before moving off to establish whether sufficient clearance exists to prevent the vehicle grounding.



Wheeled and light tracked machines should be restrained so that the effect of bouncing caused by road shocks transmitted from the carrying vehicle and amplified by the machine's tyres or suspension units is minimised. Where possible, the suspension unit of the machine should be locked and vertical movement limited by lashings or other means of restraint. Otherwise the machine's frame or chassis should be supported on blocks. Unless the machine is supported, the full contact area of its tracks or drums, and minimum half the tyre width should rest on the deck of the carrying vehicle. If the tracks extend outside the frame of the carrying vehicle then the machine's frame or chassis should be supported.

The machine should be restrained against forward, backward and sideways movement by chain or webbing lashings attached to anchorage points on the vehicle. All lashings should incorporate some form of tensioning device.

In deciding the number of anchorage points to be used when arranging a restraint system, the following factors should be considered:

1. The need to position the machine to achieve the correct load distribution to meet the legal axle load requirements and to ensure that the vehicle's handling is not impaired.
2. The extent to which other load restraint features is incorporated in the design of the vehicle.
3. Whether the machine has wheels, tracks or rollers.
4. The weight of the machine to be carried.
5. A minimum of four lashings should be used.
6. A minimum of four separate anchorage points should be used.
7. Top-over lashing placed over the top of the driver cabin or covers of mobile machines is not recommended.

**WARNING:** Vehicles should never be driven, no matter how short a distance, with any equipment extended or in an unlocked position.

## 8.5 Transport of cars, vans and small trailers

This section addresses transport of vehicles (further on "transported car") of category M1 and N1 on other road vehicles (further on "car transporter"). It is strongly recommended only to use car transporters, which are particularly designed for this purpose.

The guidelines presented below do not countermand any guidelines provided by the car transporter's manufacturer. Hence, it is strongly recommended that manufacturers of car transporters provide guidelines for securing of transported cars which are tailored for the respective car transporter. This includes that the car transporter's user manual may apply different limits for the maximum mass of transported cars.



Legal provisions for maximum length, height, width and mass have to be particularly considered with car transporters.

Only if there are no guidelines provided by the car transporter's manufacturer, the following guidelines shall apply by default.

If a car transporter is equipped with manoeuvrable ramps and platforms, these shall not be operated without previous instruction by either an informed person or a comprehensive user manual. In particular, transported vehicles shall be loaded according to the provisions of the manufacturer with regard to the position of the manoeuvrable ramps and platforms during the journey. The guidelines by the manufacturer about how to secure the ramps and platforms during the journey have to be applied. All measures provided to improve operators safety, such as hand rails and ladders shall be used according to the user manual to be provided by the manufacturer. It is strongly recommended that a copy of these manufacturer's guidelines is available during the journey, for consideration by police or technical road side inspection.

Since transported vehicles are generally not built to move backwards at high speed, they shall preferably be loaded in forward direction. They shall be placed with their centres of gravity in the longitudinal vertical centre plain or the vehicle in order to ensure equal lateral load distribution. Optimal vertical load distribution is achieved if heavier vehicles are stowed on the lower platform.

If not fully loaded, the guidelines on load distribution have to particularly be considered, including minimum and maximum axle loads of the car transporter and, in case, its trailer. Further, vertical load distribution has to be particularly considered. Generally, the centre of gravity shall be kept as low as possible.

Securing of the vehicles is achieved by a combination of friction, blocking and lashing:

- a) Friction:  
According to the owner's manual of the transported vehicle, all devices keeping this vehicle in its position shall be used, e.g. gear shift in "parking" position, first or reverse gear; manual or electronic brakes activated.
- b) Blocking:  
Wheels blocked by placing a wedge or bar in front and/or behind the respective wheel. Preferably, these wedges or blocking bars are tailored to function on the car transporter and can be locked in their position. Otherwise, the wedges or bars have to be fastened to the load platform in order not to leave their position during the journey. Alternatively, wheels may rest each in a chamfer. The effective height of all kind of blocking devices shall be at least about 17% of the wheel diameter.
- c) Lashing:  
Wheels secured by top over lashing. Web lashings according to EN12195-2 shall be used. LC shall be 1500 daN at least. The web lashing shall be connected directly to the load platform on both ends. It shall run over the tyre tread in longitudinal direction and fixed to the platform as close to the tyre as possible. In order to reasonably place the lever brace, the lashing may be diverted by specific devices or by the blocking bars. The same applies respectively to wheels resting within chamfers.

In general, two wheels of a transported car shall be secured by wedges in front and behind the wheels plus lashings according to the provisions under letters b) and c) above. Preferably, two diagonally opposite wheels are secured. For the last vehicle at the end of the car transporter, one additional wheel shall be secured, which is the one on the axle closer to the rear end of the car transporter.

For transported cars loaded in forward direction, the securing on the front wheel may be replaced by a blocking wedge or bar in front of one front tyre.

For vehicles loaded on a sloping platform, three wheels are required to be secured, where one of them has to include securing with two wedges and a lashing according to letter b) and c) above. The other two wheels have to be secured according to letter b) with two wedges or a lashing according to letter c).



Lashing only (letter c)



Lashing and blocking (letters b and c)



It is not recommended to secure sprung vehicles by lashing their sprung mass directly to the car transporter. If such a method is applied notwithstanding, it shall be subject to individual assessment. The numerous parameters which have to be considered to develop such a method, do not allow application of general guidelines like the one above valid for securing of sprung vehicles via their unsprung parts (i.e. normally via the wheels).

### 8.6 Transport of trucks, trailers and chassis on trucks

This section addresses transport of heavy vehicles (further on “transported heavy vehicle”) of category M2 and M3, N2 and N3 as well as O3 and O4 on other road vehicles (further on “heavy vehicle transporter”). These guidelines do not countermand any guidelines provided by the heavy vehicle transporter’s manufacturer. Hence, it is strongly recommended that manufacturers of heavy vehicle transporters provide guidelines for securing of transported heavy vehicle which are tailored for the respective heavy vehicle transporter. This includes that the heavy vehicle transporter’s user manual may apply different limits for the maximum mass of transported heavy vehicles.

If there are no guidelines provided by a heavy vehicle transporter’s manufacturer, the following guidelines apply by default for trucks and trailers from 4 to 20 t actual weight with a wheel diameter of max. 1.25 m.

In general, the same principles apply as for vehicles of categories M1 and N1 in the previous chapter. However, the web lashings to be used shall have a strength of at least LC=2500 daN.

Two diagonally opposite wheels shall be secured. For transported heavy vehicles with more than two axles, each additional axle shall be secured by one additional lashing. Wedges or blocking bars are not required for these additional lashings.



## 8.7 Transport of coils

### 8.7.1 Coils of more than 10 ton

Heavy coils such as steel or aluminium coils are preferably transported in a vehicle that is purpose built for this application, the so-called coil carrier.

A coil carrier has a wedge shaped hole parallel to the driving direction in the floor of the vehicle. The angles of the wedge are typically between 29 and 35° inclined to the horizontal plane. As long as the weight of the coil is supported by the inclined part of the wedge, no further securing arrangements to prevent sliding and rolling in sideward direction are required. Sliding in the longitudinal direction can be prevented by using high quality anti-slip mats. However these mats do not prevent a coil to “telescope”. Telescoping strongly depends on the tightness of the windings of a coil, on the friction between succeeding layers in a coil and on the packaging of the coil. However, even several steel straps do not prevent telescoping of poorly wound heavy coils of slippery material. Two poles in front of the coil (gap smaller than 40mm) prevent sliding and telescoping in forward direction. A spring lashing on both the left hand side and the right hand side of the coil prevent sliding and telescoping in the backward direction. The required minimum blocking capacity of the poles and the lashings depends on the mass of the coil and the tendency to telescope. The major requirements for tightly wound steel coils that are not tilt sensitive, are summarised in the picture below. A practical test is recommended to determine values for other types of coils.

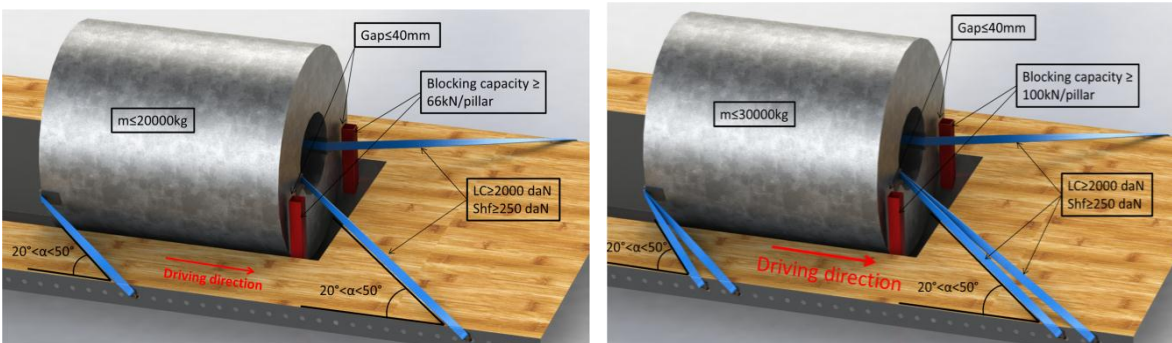

Short coils with large diameters can be tilt sensitive. Tilting of such coils can be prevented by grouping several coils together to form one unit or by using higher poles of sufficient strength in front of the coil(s). As an alternative, a horizontal blocking bar that is fixed on rigid vehicle walls can be used.



If a coil carrier is not available, a specific steel construction to prevent sliding, rolling, tilting and telescoping of the coil is strongly recommended as illustrated in the pictures below.

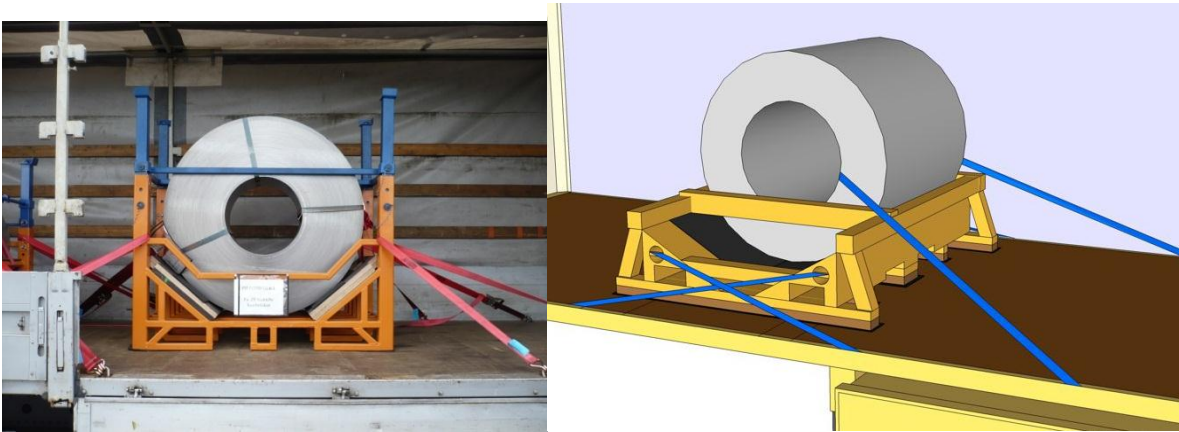

### 8.7.2 Coils of less than 10 ton

Low and medium weight steel and aluminium coils (and similar) are preferably transported on a coil carrier as described in paragraph 8.10.a.

As an alternative, a wedge bed can be used. A wedge bed is a construction for a coil with bore horizontal:

- the wedges on which the coil rests ought to go over the whole width of the coil;
- there should be a provision to fix the spacing between the wedges of the wedge bed;
- stable support and free space under the coil;

Any of the securing arrangements shown below could be used for coils in a wedge bed depending of the coil weight. The required lashing capacity depends on the mass of the coil and on the quality of the packaging that helps to prevent telescoping. It is recommended to always use friction mats

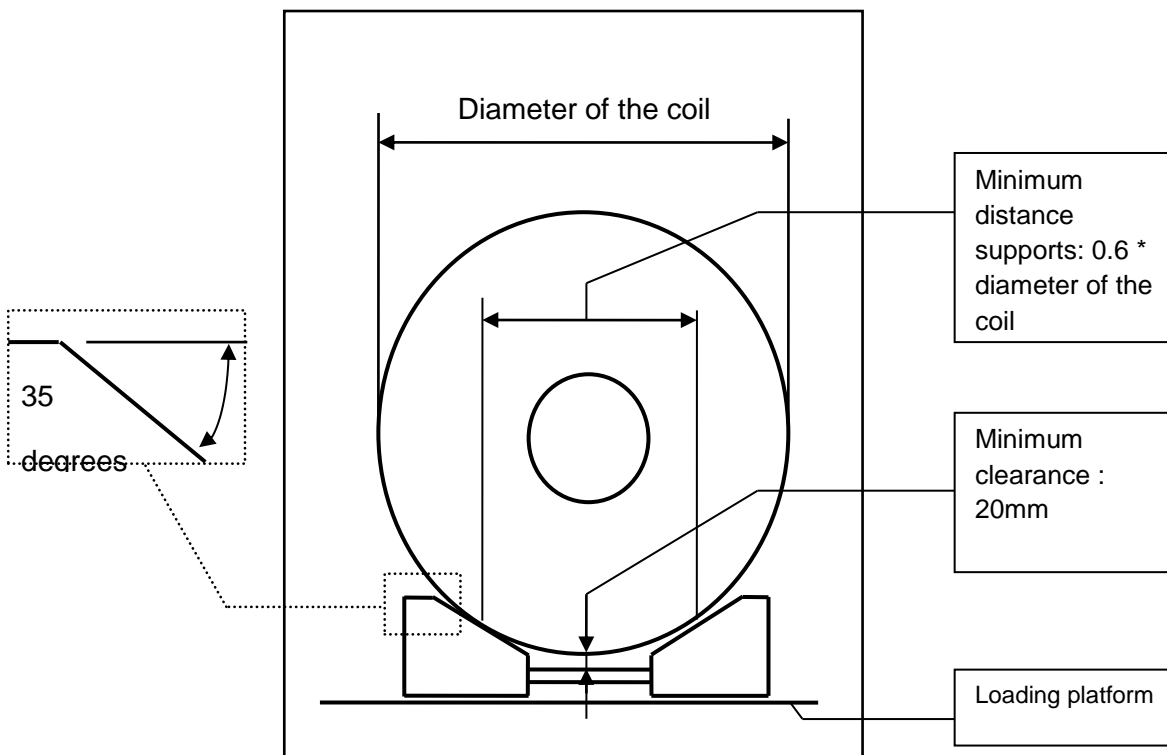

*Characteristics of a wedge bed*

between the coil and the wedge bed as well as between the wedge bed and the floor.

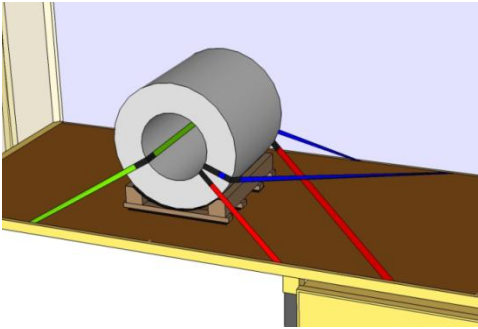

Figure x Low coil weight

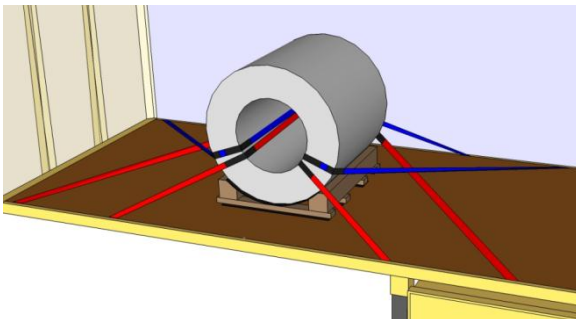

Figure x Medium coil weight



## 8.8 Beverages

Cargo securing of beverages is quite challenging if the rigidity of the load units is not certified. Pull over lashing as such is not possible since the lashings tend to damage the beverages. Specific pallet covers or empty pallets can theoretically be used to allow pull down lashing. However, non-carbon drinks in PET bottles can easily buckle under a combination of downward lashing forces and transverse inertia forces. Horizontal grouping per four load units is recommended.

In case beverages have to be transported regularly, a specific vehicle for beverage transport should be used. Such a vehicle is usually built with a better than XL coded inclined roll-up curtains that pull the beverages towards the middle of the vehicle. Till today these vehicles do have a fixed or removable fence in the longitudinal symmetry section. The beverages are blocked in the forward direction by the headboard and in some cases by intermediate fences.

## 8.9 Transport of palletized goods

The most common pallet used for goods transportation is the EUR0 pallet (ISO 445-1984). It is made primarily of wood, and the standard dimensions are 800x1200x150 mm.

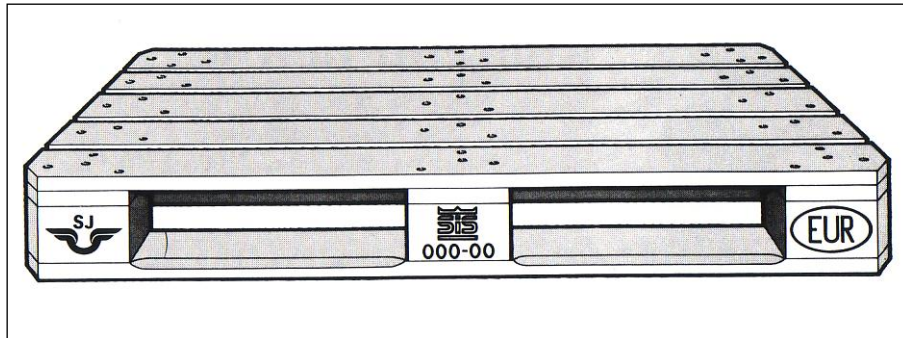

*Euro-pallet*

When cargo boxes of a size equal to or smaller than the pallet are loaded on a pallet, the pallet constitutes a load carrier similar to a load platform without sideboards. Measures to prevent the cargo from sliding or tipping in relation to the pallet should be taken by lashing means similar to the methods described above. The friction between the surfaces of the cargo and pallet are therefore important for calculating the cargo securing. The ratio of the loaded pallet height/width and weight also has to be taken into account (here the loaded pallet's weight corresponds to the weight of a cargo section).

Any means of securing the load to the pallet, e.g. lashing, shrink wrapping, etc... can be used as long as the load pallet is able to withstand a sideways tilt angle of at least 26.6° without any significant sign of distortion.

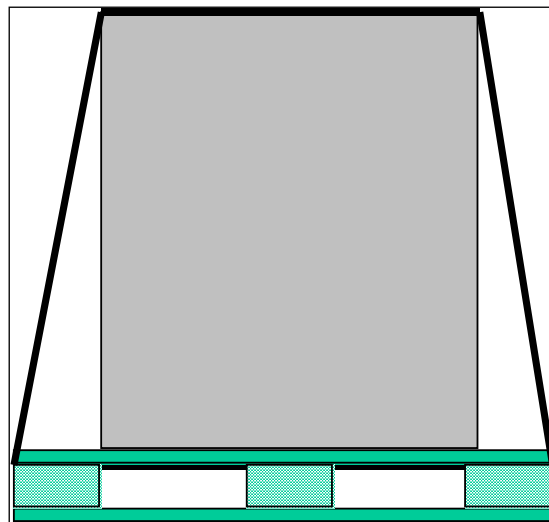

*Cargo unit lashed to a Euro-pallet*

Framed pallets are commonly used for food transportation. Securing the wheeled pallets by blocking is particularly effective; however, alternative methods may be used.

To obtain the largest safety for a full load of double stacked euro pallets in a XL coded vehicle, it is recommended to stow the pallets in the following way:

- in the 15 forward sections the pallets are stowed in transverse direction in two rows (30 pallet places).
- in the rear section the pallets are stowed in longitudinal direction in three rows (3 pallet places).

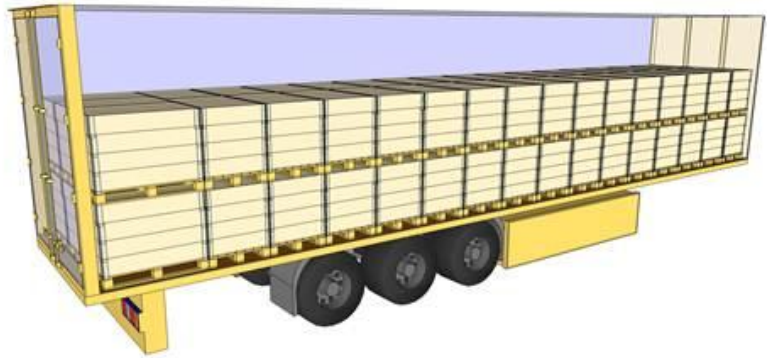

Specialized pallets such as wheel pallets are widely used for distributions.

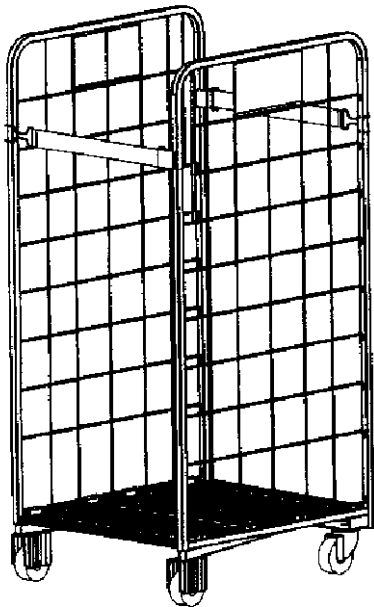

*Wheel pallet with side supports and clipping bars*

## 8.10 Transport of palletized goods using cross lashing

For transport of palletized goods such as palletized bags - well packed with a shrink- or stretch hood or wrapped stretch film - a specific combination of lashings can be used. This combination is called "cross lashing" and combines the securing effects of grouping, of top-over lashing and of direct lashing. It can be applied for all pallet dimensions, for full truck loads as well as partial loads. Cross top lashing and cross spring lashing are possible when tested and certified.

Basically a cross top lashing consists of two conventional web lashings for a group of two pallet loads or a group of four pallet loads. Both lashings are applied as a conventional top-over lashing,

but the lashing points on both sides of the vehicle are shifted, thus creating a cross on the top surface of the group of pallet loads as illustrated in figures 1 and 2.

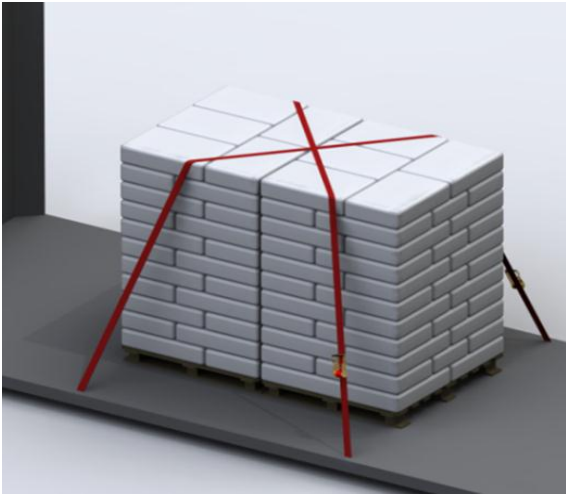

Figure 1: Two pallets with cross lashing

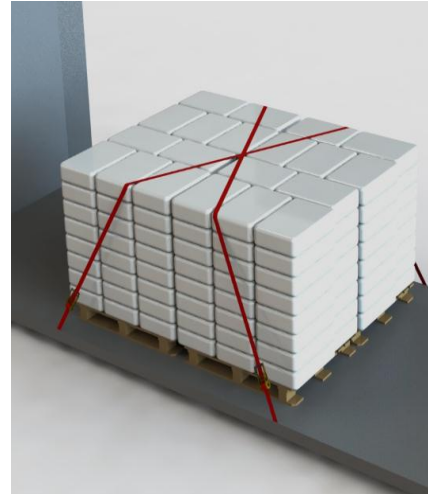

Figure 2: Four pallets with cross lashing

The cross top lashing can prevent the pallets from sliding and tilting in both transverse directions.

The effectiveness of the cross top lashing over deformable products cannot be calculated since it depends on friction, mass, dimensions and on the actual product deformation. Therefore the effectiveness should be validated by testing. A test according to EN12642 annex B or EN 12195-1 annex D shall show the capability of the pallet loads with the cross top lashings to withstand the g-forces as required.

In some situations the cross top lashing as described is insufficient to withstand the inertia forces in the driving direction. In such a case a so called cross spring lashing can be applied. Each web lashing is pulled in front of one top front corner of the group of pallets as illustrated in figure 3. Such a cross spring lashing generates a restraining force in the driving direction comparable with a conventional spring lashing.

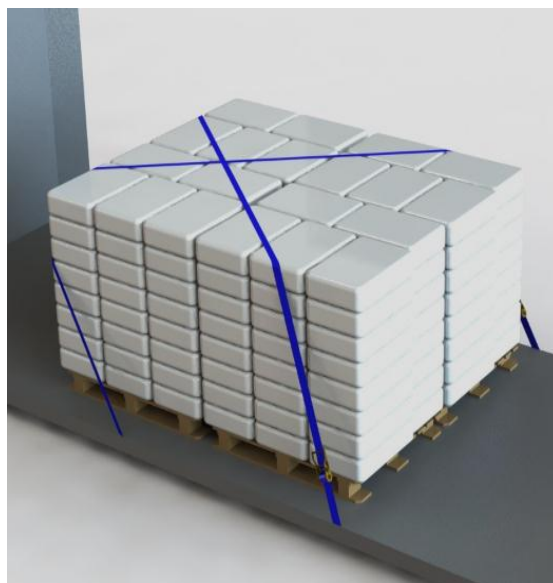

Figure 3: Four pallets with cross spring lashing

Depending on the actual type of load, a specific combination of both types of cross lashings and blocking can be used. Figure 4 shows a very practical combination: blocking by a headboard, one or two cross spring lashings and one cross top lashing for the remaining groups of pallet loads.

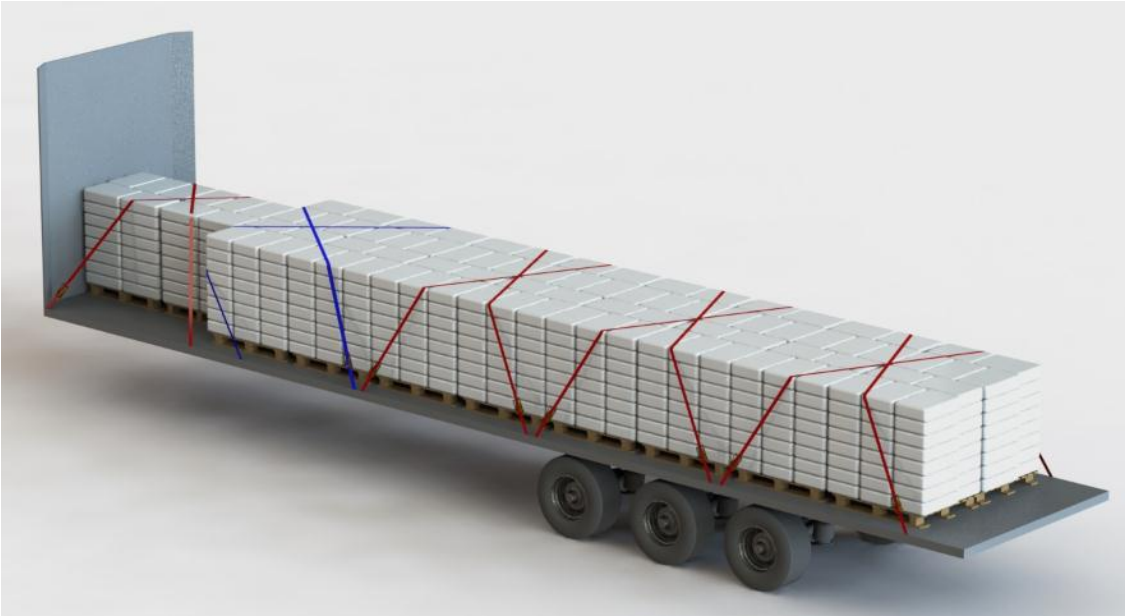

Figure 4: Trailer with a combination of blocking, cross top- and spring lashing

## 8.11 Mixed loads

All parts of a mixed load should be secured to prevent sliding, tipping and wandering in all directions. Mixed loads are preferably secured by blocking but additional securing by lashings may be required. In principle each type of load can be secured as described in the previous sections or according to the instructions in the Quick Lashing Guide.



## Appendix 1 Symbols

$F_A$ : acceleration force

$F_F$ : friction force

$F_D$ : direct lashing force

$F_B$ : blocking force

$F_C$ : contact force between the vehicle superstructure and a piece of cargo or between 2 pieces of cargo

$F_T$ : effective tension force in a web lashing

LC : lashing capacity of a lashing, defined in EN12195-2/4

$S_{TF}$ : standard tension force of a lashing, defined in EN12195-2/4

$S_{HF}$ : standard hand force of a lashing, defined in EN12195-2/3

$m$  : mass

$\beta_x$  : angle between horizontal projection of direct lashing and longitudinal direction

$\beta_y$  : angle between horizontal projection of direct lashing and transverse direction

$\alpha$ : angle between lashing and horizontal plane

$\mu$ : friction factor as defined in EN12195-1:2010

HG: Height of centre of gravity above loading platform

LG: horizontal distance between tilting axis and centre of gravity

RBC: reference blocking capacity

## Appendix 2 Quick Lashing Guide

The quick lashing guide offers practical, simplified instructions for securing cargo in accordance with the formulas in the European standard EN 12195-1:2010 as well as the principles set out in these guidelines.

### A.2.1 Procedure and limitations

The lashing tables in this Quick Lashing Guide show the cargo weight in ton (1000 kg) prevented from sliding or tipping per lashing. The values in the tables are rounded to two significant figures.

“no risk” indicated in the tables means that there is no risk of the cargo sliding or tipping. Even if there is neither sliding nor tipping risk, it is recommended to use at least one top-over lashing per every 4 ton of cargo or similar arrangement to avoid wandering for non-blocked cargo due to vibrations.

### A.2.2 The cargo securing arrangement must carry...

- ... 0.8 of the cargo weight forwards
- ... 0.5 of the cargo weight sideways and towards the rear
- ... 0.6 of the cargo weight sideways if there is risk of the cargo tipping

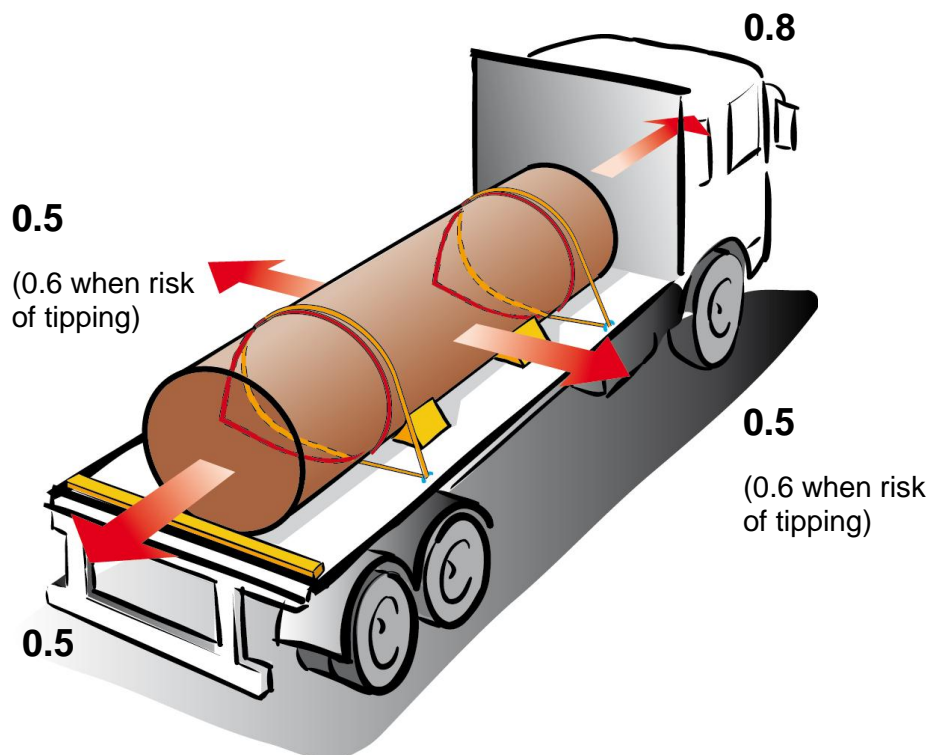

### A.2.3 Conditions for securing with this Quick Lashing Guide

The cargo must be prevented from sliding and tipping in all directions when exposed to forces occurring during transport.

The securing of cargo must be done using locking, blocking, lashing or a combination of these techniques.

#### Lashing equipment

The values in the tables in this Quick Lashing Guide have been calculated on the assumption that the;

... *lashing points* resist 2000 daN  
(2 tons under stress)

... *lashings* have a Lashing Capacity  
(LC) of 1600 daN (1.6 tons under stress)

... *lashings* with STF = 400 daN  
(tightened to 400 kg).

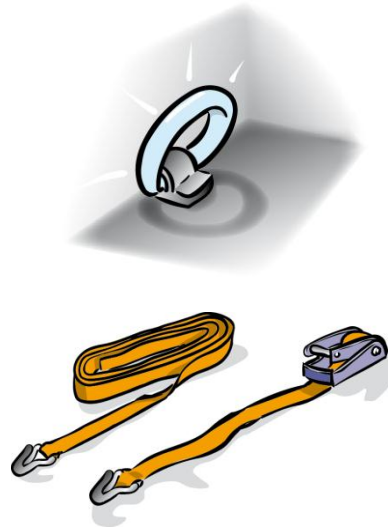

The lashings must be tightened to a minimum of 400 daN (400 kg) throughout the transport.

## A.2.4 Blocking

Where possible blocking should be used as method to secure the cargo

Blocking involves positioning the cargo, or parts of the cargo directly to the headboard, sideboards, stanchions, supports, walls or parts of the cargo to stop it from moving. In case of global blocking, the sum of void spaces in any horizontal direction should not exceed 15 cm. However, between dense and rigid cargo items, such as steel, concrete or stone, void spaces should be further minimized, as far as possible.

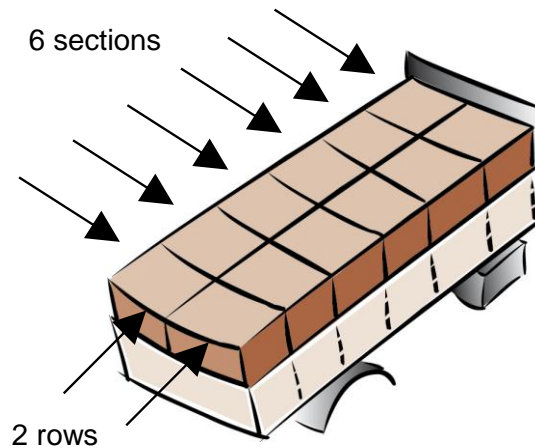
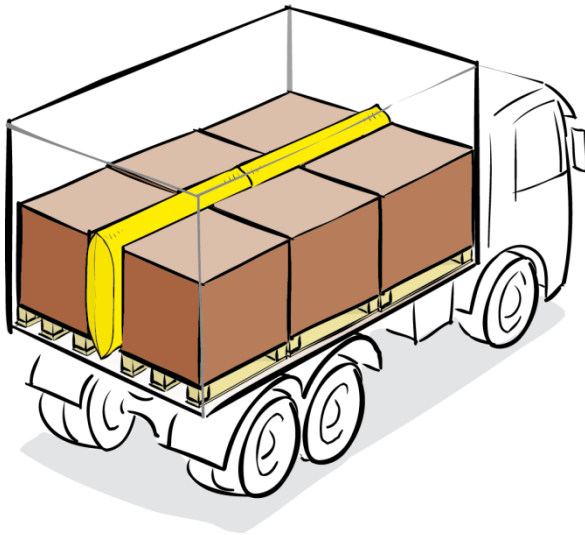

If the cargo is blocked to a sufficient height, this will effectively stop it from sliding and tipping.

If the cargo is only bottom blocked, lashing may be needed to prevent tipping, see the tipping tables in this Quick Lashing Guide.

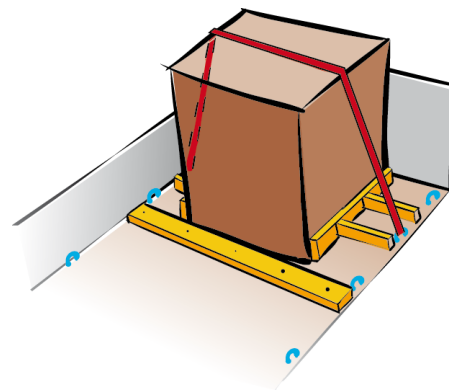

## Headboard and rear wall

Headboards and rear walls on vehicles with a payload over 12.5 tons built in accordance with EN 12642 L.

### Headboard - EN 12642 L

<b>Friction factor, <math>\mu</math></b>	<b>Cargo weight in ton possible to block against the headboard in forward direction</b>
0.15	7.8
0.20	8.4
0.25	9.2
0.30	10.1
0.35	11.3
0.40	12.7
0.45	14.5
0.50	16.9
0.55	20.3
0.60	25.4

### Rear wall - EN 12642 L

<b>Friction factor, <math>\mu</math></b>	<b>Cargo weight in ton possible to block against the rear wall towards the rear</b>
0.15	9.0
0.20	10.5
0.25	12.6
0.30	15.8
0.35	21.0
0.40	31.6

*If the weight of the cargo is greater than that shown in the tables, then in addition to blocking, lashing will be required.*

**100mm (4'') nail**



<b><u>100mm (4'') – NAIL</u></b>						
<b>Cargo weight in ton prevented from sliding per nail</b>						
<b>μ</b>	<b>Sideways</b>		<b>Forwards</b>		<b>Towards the rear</b>	
	<b>Each side – <u>100 mm (4'')- nail</u></b>		<b><u>100mm (4'') - nail</u></b>		<b><u>100mm (4'') - nail</u></b>	
	<b>Plain</b>	<b>Galvanized</b>	<b>Plain</b>	<b>Galvanized</b>	<b>Plain</b>	<b>Galvanized</b>
0.2	0.36	0.53	0.18	0.26	0.36	0.53
0.3	0.55	0.80	0.22	0.32	0.55	0.80
0.4	1.1	1.6	0.27	0.40	1.1	1.6
0.5	no risk	no risk	0.36	0.53	no risk	no risk
0.6	no risk	no risk	0.55	0.80	no risk	no risk
0.7	no risk	no risk	1.1	1.6	no risk	no risk

*These values are taken from the IMO Model Course 3.18 and recalculated in accordance with EN 12195-1: 2010.*

**Unlashed cargo and the risk of movement**

If there is no risk of a cargo sliding or tipping (as shown in the tables of this guide) the cargo can be transported without the use of lashing straps.

Even if there is neither sliding nor tipping risk, as a rule of thumb, it is recommended to use at least one top-over lashing per every 4 ton of cargo or similar arrangement to avoid wandering for non-blocked cargo due to vibrations.

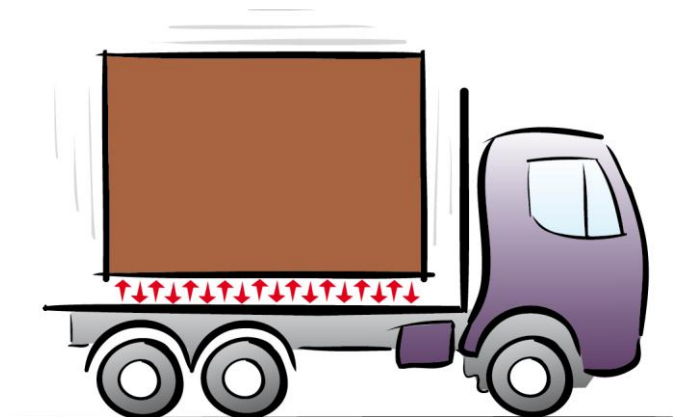

## A.2.5 Other ways to secure cargo

Cargo can also be secured by using friction or lashing methods.

### Calculation for lashing requirements

If lashing are used to stop the cargo from moving, then;

1. Calculate the number of lashing straps needed to prevent a sliding movement.
2. Calculate the number of lashing straps needed to prevent the cargo from tipping.
3. The highest number of these two values shows the minimum number of lashing straps needed.

### Supporting edge profile

In some cases, less lashing straps than the number of sections of the cargo can be used. Each section of the cargo must be secured.

A 'supporting edge profile' may be used to spread the effects of each lashing. These profiles may be constructed of wooden planks (at least 25mm x 100mm). Other material with the same strength values can also be used, such as aluminium or similar material. At least one lashing strap should be used, for every 2<sup>nd</sup> section of the cargo, with one at each end.

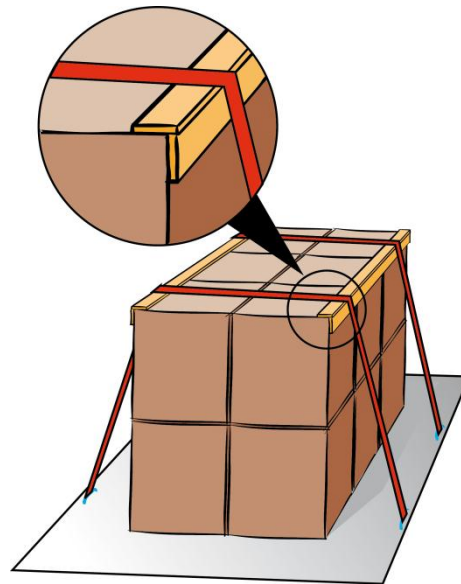

## A.2.6 Sliding

The friction between the cargo and the loading platform (or cargo beneath it) has a huge influence on how much one lashing can prevent from sliding.

The table in Appendix 4 gives the typical friction factors for common combinations of materials contacting each other or the vehicle load platform.

The values in the table are valid for dry and wet surfaces when the contact surfaces are clean, undamaged and without frost, ice or snow. If this is not the case, then a friction factor ( $\mu$ ) = 0.2 should be used. Special precautions shall be taken if the surfaces are oiled or greasy.

In case of direct lashings, where the cargo may move a little before the elongation of the lashings provides the desired restraint force, the dynamic friction applies, which is to be taken as 75 % of the friction factor. This effect is included in the tables in the Quick Lashing Guide.

## A.2.7 Tipping

To find out the maximum cargo weight prevented from tipping, refer to the tables in this Quick Lashing Guide.

The H/B (height divided by the breadth) or H/L (height divided by the length) of cargo to be secured must be calculated.

**The calculations must be rounded up to the nearest higher value shown in the tables.**

### Cargo items with the centre of gravity close to their centre

The following sketches explain how to measure the H (height), L (length) and B (breadth) of the cargo.

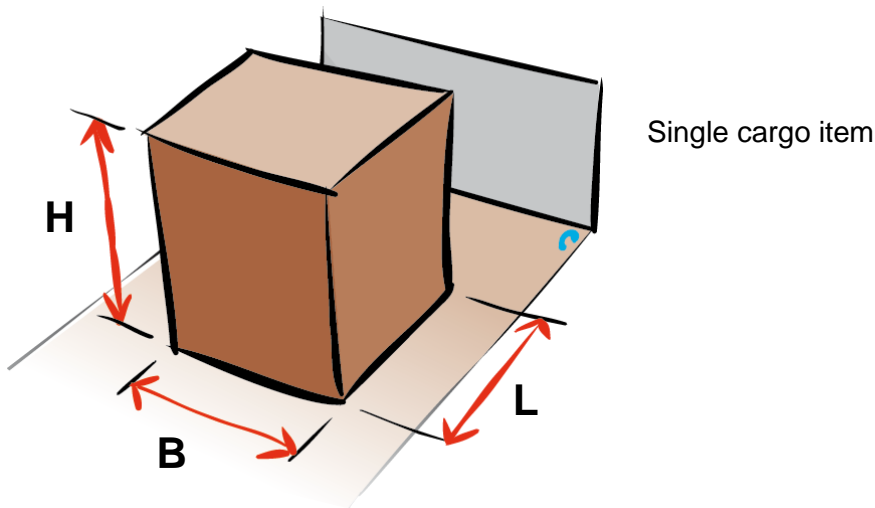

A section of the cargo  
(showing three rows and  
two layers)

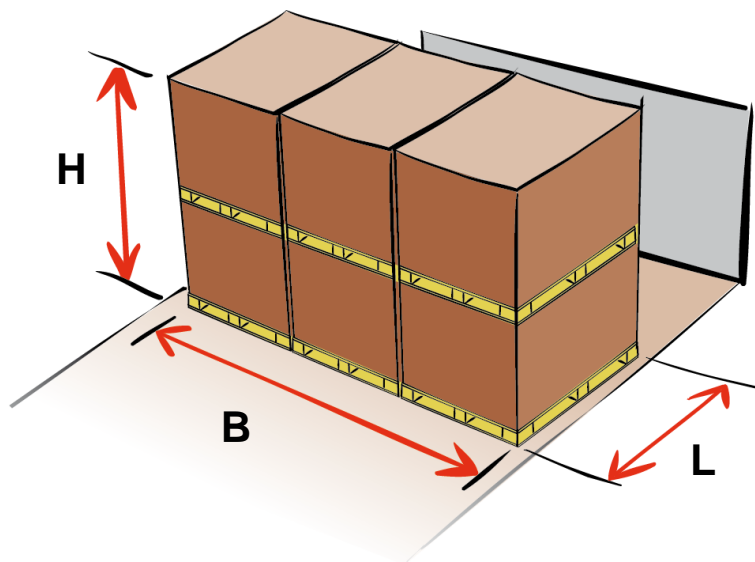

## Cargo items with displaced centre of gravity

If the cargo item to be secured has a centre of gravity above its centre or out to the side, then the H, B and L measurements should be done as shown in the diagram below.

H = *Distance up to the centre of gravity*

B = *Shortest distance between the centre of gravity and the sideways tipping point*

L = *Distance according to the diagram*

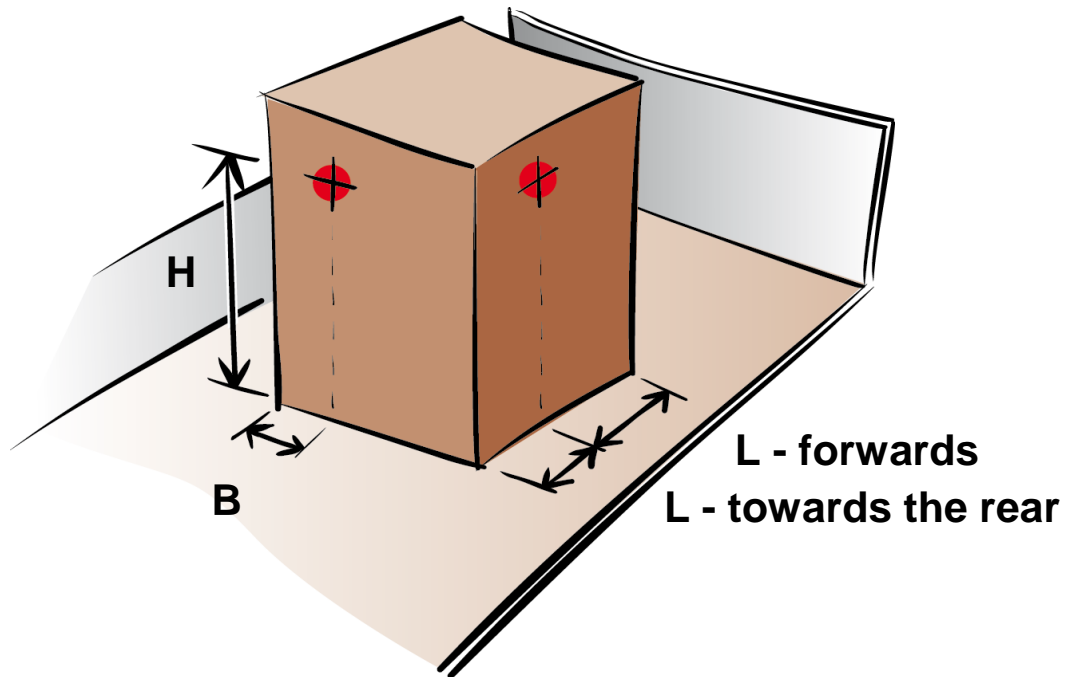

## A.2.8 Loop lashing

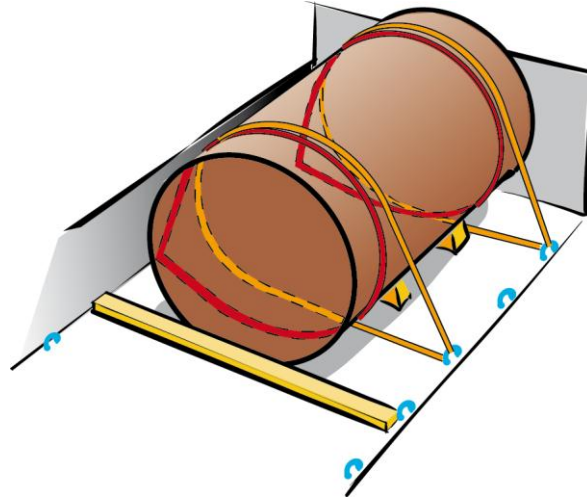

A loop lashing will secure a cargo item on each side with a pair of webbings. At the same time the cargo will be prevented from tipping. At least two loop lashings per long cargo item should be used.

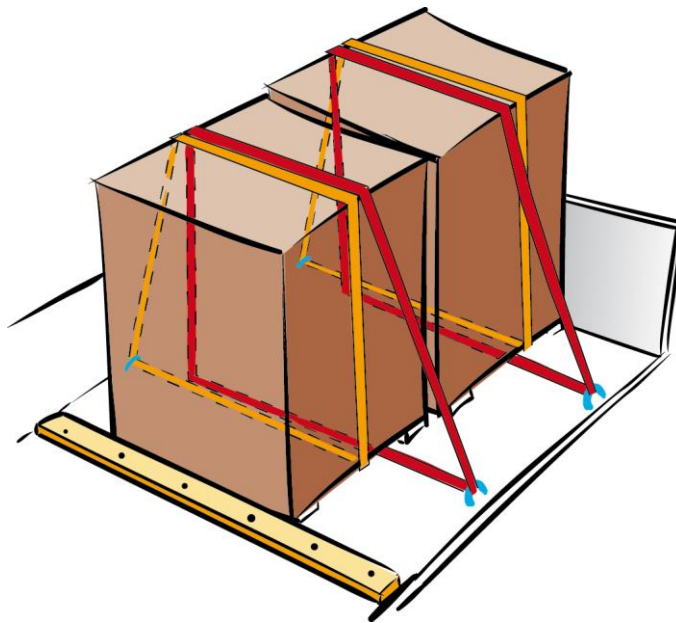

If the cargo item contains more than one section and the sections support each other and stop any twisting from occurring, then only one loop lashing per section of the cargo, may be needed.

Cargo weight in ton prevented from sliding				
<i>per pair of loop lashing</i>				
$\mu^*$	Sideways		$\mu^*$	Sideways
0.15	4.7		0.45	13
0.20	5.4		0.50	no risk
0.25	6.2		0.55	no risk
0.30	7.3		0.60	no risk
0.35	8.7		0.65	no risk
0.40	11		0.70	no risk

\* Friction factor according to Appendix 4

Cargo weight in ton prevented from tipping					
<i>per pair of loop lashing</i>					
Sideways					
<i>H/B</i>	1 row	2 rows	3 rows	4 rows	5 rows
0.6	no risk	no risk	no risk	6.5	4.1
0.8	no risk	no risk	5.6	3.1	2.3
1.0	no risk	no risk	3.1	2.0	1.6
1.2	no risk	4.6	2.1	1.5	1.3
1.4	no risk	3.0	1.6	1.2	1.0
1.6	no risk	2.2	1.3	1.0	0.86
1.8	no risk	1.8	1.1	0.86	0.74
2.0	no risk	1.5	0.94	0.75	0.65
2.2	5.1	1.2	0.83	0.67	0.58
2.4	3.7	1.1	0.74	0.60	0.53
2.6	2.9	0.96	0.66	0.54	0.48
2.8	2.4	0.86	0.61	0.50	0.44
3.0	2.0	0.78	0.56	0.46	0.41
3.2	1.8	0.72	0.51	0.43	0.38

*The values in these tables will apply only when each end of the loop lashing is fastened at different lashing points. If both ends of a loop lashing are fastened to the same lashing point, then this point must hold 1.4 x lashing LC.*

## A.2.9 Spring lashing

A spring lashing is used to stop movement of a cargo item forwards and/or towards the rear. It is important that the angle between the loading platform and the lashing strap does not exceed 45°.

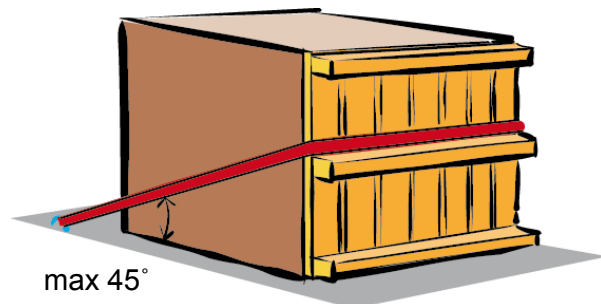
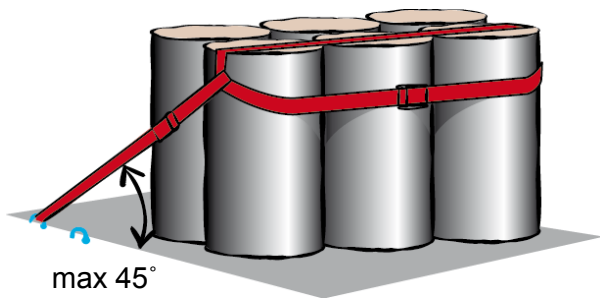

The spring lashing can be done in many ways. However, if the lashing is not applied to the upper edge of the cargo item, the tipping limits of the cargo weight is reduced.

For example, if the spring lashing is placed half way up the cargo item, then it will only secure half the cargo weight indicated in the table.

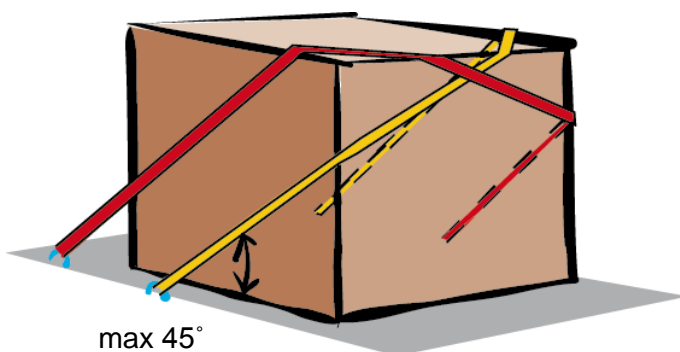

*This spring lashing set-up has two legs on each side, which secures twice the weight that is indicated in the table.*

Cargo weight in ton prevented from sliding <i>per</i> spring lashing					
$\mu^*$	Forwards	Towards the rear	$\mu^*$	Forwards	Towards the rear
0.15	3.7	6.6	0.45	6.7	19
0.20	4.1	7.6	0.50	7.5	no risk
0.25	4.5	8.8	0.55	8.4	no risk
0.30	4.9	10	0.60	9.6	no risk
0.35	5.4	12	0.65	11	no risk
0.40	6.0	15	0.70	13	no risk

\* Friction factor according to Appendix 4

Cargo weight in ton prevented from tipping <i>per</i> spring lashing		
H/L	Forwards	Towards the rear
1.2	no risk	no risk
1.4	54	no risk
1.6	26	no risk
1.8	19	no risk
2.0	15	no risk
2.2	13	101
2.4	12	55
2.6	11	40
2.8	10	32
3.0	9.9	28
3.2	9.5	25

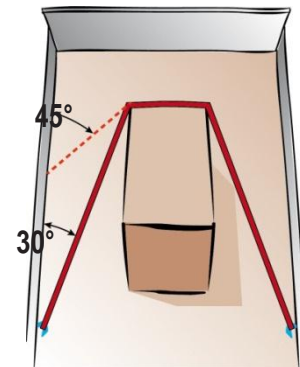

If the angle sideways exceeds 5° the table values must be reduced with:

Angle 5°- 30° ⇒ 15%

Angle 30°- 45° ⇒ 30%

## A.2.10 Direct lashing

Lashings must be fixed within the green angles, as shown in the diagram.

This will ensure that they secure the individual cargo item in accordance with the table values.

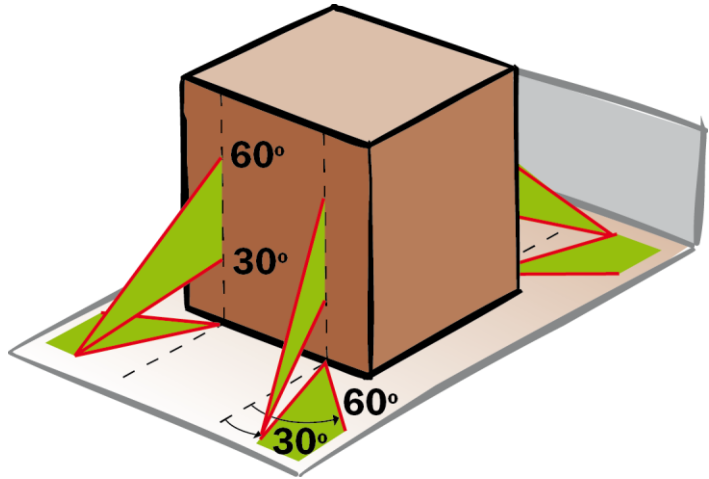

Left and right lashings

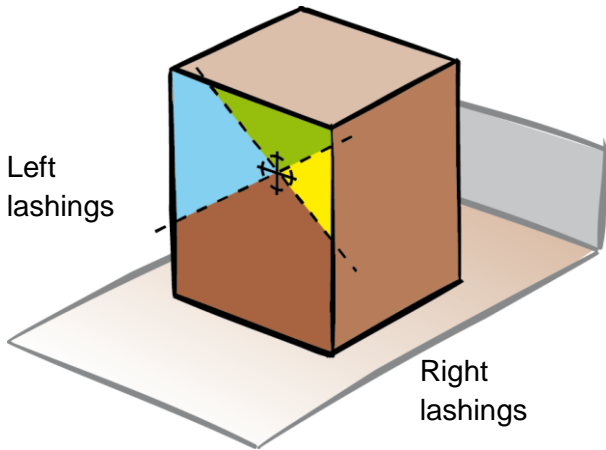

The areas where you can attach lashing straps are limited by two straight lines running diagonally through the centre of gravity at an angle of 45°.

Cargo weight in ton prevented from sliding							
<i>per</i> straight lashing							
$\mu^*$	Sideways	Forwards	Towards the rear	$\mu^*$	Sideways	Forwards	Towards the rear
0.15	1.5	0.82	1.5	0.45	5.4	1.9	5.4
0.20	1.8	0.95	1.8	0.50	no risk	2.2	no risk
0.25	2.2	1.1	2.2	0.55	no risk	2.6	no risk
0.30	2.6	1.3	2.6	0.60	no risk	3.0	no risk
0.35	3.3	1.4	3.3	0.65	no risk	3.5	no risk
0.40	4.2	1.7	4.2	0.70	no risk	4.2	no risk

\* Friction factor according to Appendix 4

Cargo weight in ton prevented from tipping					
<i>per</i> straight lashing					
H/B	Sideways	H/L	Forwards	Towards the rear	
1.2	no risk	1.2	no risk	no risk	
1.4	no risk	1.4	8.2	no risk	
1.6	no risk	1.6	3.8	no risk	
1.8	no risk	1.8	2.6	no risk	
2.0	no risk	2.0	2.0	no risk	
2.2	4.1	2.2	1.7	13.0	
2.4	3.2	2.4	1.5	6.9	
2.6	2.6	2.6	1.4	4.9	
2.8	2.3	2.8	1.2	3.9	
3.0	2.0	3.0	1.2	3.3	
3.2	1.9	3.2	1.1	2.9	

## A.2.11 Top-over lashing

Using the table below, you must note that the angle between the lashing and the loading platform is of great importance. The tables should be used for angles between 75° and 90°. If the angle is between 30° and 75° double amount of lashing straps are needed, or you halve the table values.

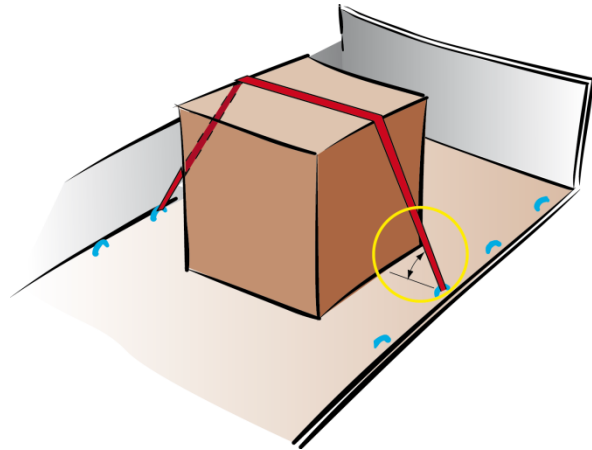

If the angle is less than 30°, then another method of securing the cargo should be used.

Cargo weight in ton prevented from sliding <i>per top-over lashing</i>			
$\mu^*$	Sideways	Forwards	Towards the rear
0.15	0.31	0.15	0.31
0.20	0.48	0.21	0.48
0.25	0.72	0.29	0.72
0.30	1.1	0.38	1.1
0.35	1.7	0.49	1.7
0.40	2.9	0.63	2.9
0.45	6.4	0.81	6.4
0.50	no risk	1.1	no risk
0.55	no risk	1.4	no risk
0.60	no risk	1.9	no risk
0.65	no risk	2.7	no risk
0.70	no risk	4.4	no risk

\* Friction factor according to Appendix 4

Cargo weight in ton prevented from tipping <i>per top-over lashing</i>								
Sideways						H/L	Forwards	Towards the rear
H/B	1 row	2 rows	3 rows	4 rows	5 rows			
0.6	no risk	no risk	no risk	5.8	2.9	0.6	no risk	no risk
0.8	no risk	no risk	4.9	2.1	1.5	0.8	no risk	no risk
1.0	no risk	no risk	2.2	1.3	0.97	1.0	no risk	no risk
1.2	no risk	4.1	1.4	0.91	0.73	1.2	no risk	no risk
1.4	no risk	2.3	0.99	0.71	0.58	1.4	5.3	no risk
1.6	no risk	1.5	0.78	0.58	0.49	1.6	2.3	no risk
1.8	no risk	1.1	0.64	0.49	0.42	1.8	1.4	no risk
2.0	no risk	0.90	0.54	0.42	0.26	2.0	1.1	no risk
2.2	4.5	0.75	0.47	0.37	0.32	2.2	0.83	7.2
2.4	3.3	0.64	0.42	0.33	0.29	2.4	0.68	3.6
2.6	2.4	0.56	0.37	0.30	0.26	2.6	0.58	2.4
2.8	1.8	0.50	0.34	0.28	0.24	2.8	0.51	1.8
3.0	1.4	0.45	0.31	0.25	0.22	3.0	0.45	1.4
3.2	1.2	0.41	0.29	0.24	0.21	3.2	0.40	1.2

*If more than one lashing is used for each section of the cargo, the tensioning devices should if possible be placed alternately on both sides.*

*The calculation values for movement forwards and towards the rear assume that lashing straps are spread equally on each section of the cargo.*

## A.2.12 Other lashing equipment

Values for LC and S<sub>TF</sub> are marked on the lashing equipment.

*If the LC for a chain is not known, the LC can be set to 50% of the breaking load.*



### Recalculating

If equipment with a different capacity to LC 1600 or S<sub>TF</sub> 400 is used, the figures in the sliding and tipping tables have to be multiplied with the following factors.

When recalculating, never use larger LC or S<sub>TF</sub> than the lashing points can hold.

### Methods

#### Loop lashing

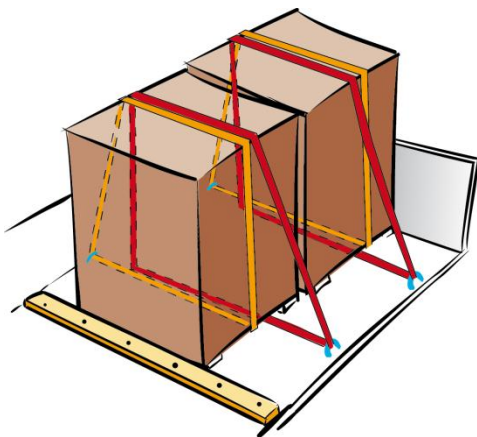

$$\frac{\text{Actual LC}}{1600} = \text{Multiplication factor}$$

**Spring lashing**

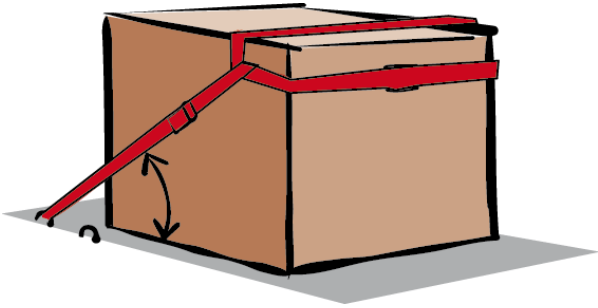

$$\frac{\text{Actual LC}}{1600} = \text{Multiplication factor}$$

**Direct lashing**

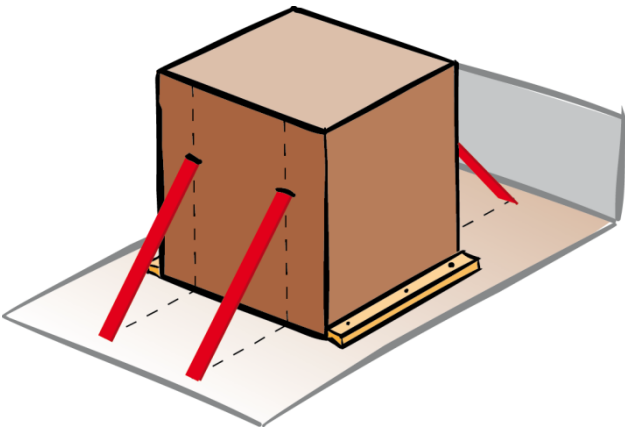

$$\frac{\text{Actual LC}}{1600} = \text{Multiplication factor}$$

**Top-over lashing**

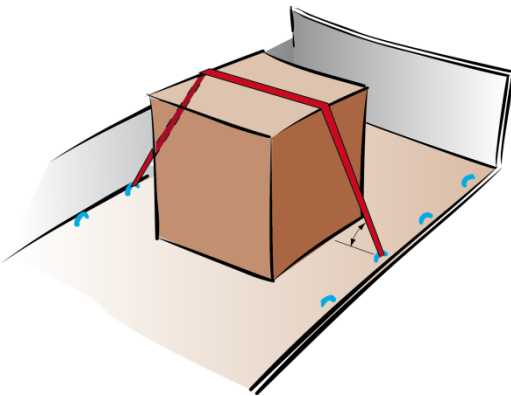

*For sliding:*

$$\frac{\text{Actual } S_{TF}}{400} = \text{Multiplication factor}$$

*For tipping the smallest of the following factors shall be used:*

$$\frac{\text{Actual } S_{TF}}{400} \text{ or } \frac{\text{Actual LC}}{1600} = \text{Multiplication factor}$$

### A.2.13 Cargo consisting of several layers

Determination of the number of top-over lashing straps needed to secure cargo items stowed in several layers when they are not blocked sideways.

#### Using the following four steps

1. Calculate the number of lashing straps needed to secure the weight of the whole section from sliding using friction in the bottom.
2. Calculate the number of lashing straps needed to secure the weight of the upper section from sliding, using friction between the upper and lower layer.
3. Calculate the number of lashing straps needed to stop tipping of the whole section.
4. The highest number of lashings from the three calculations should be used.

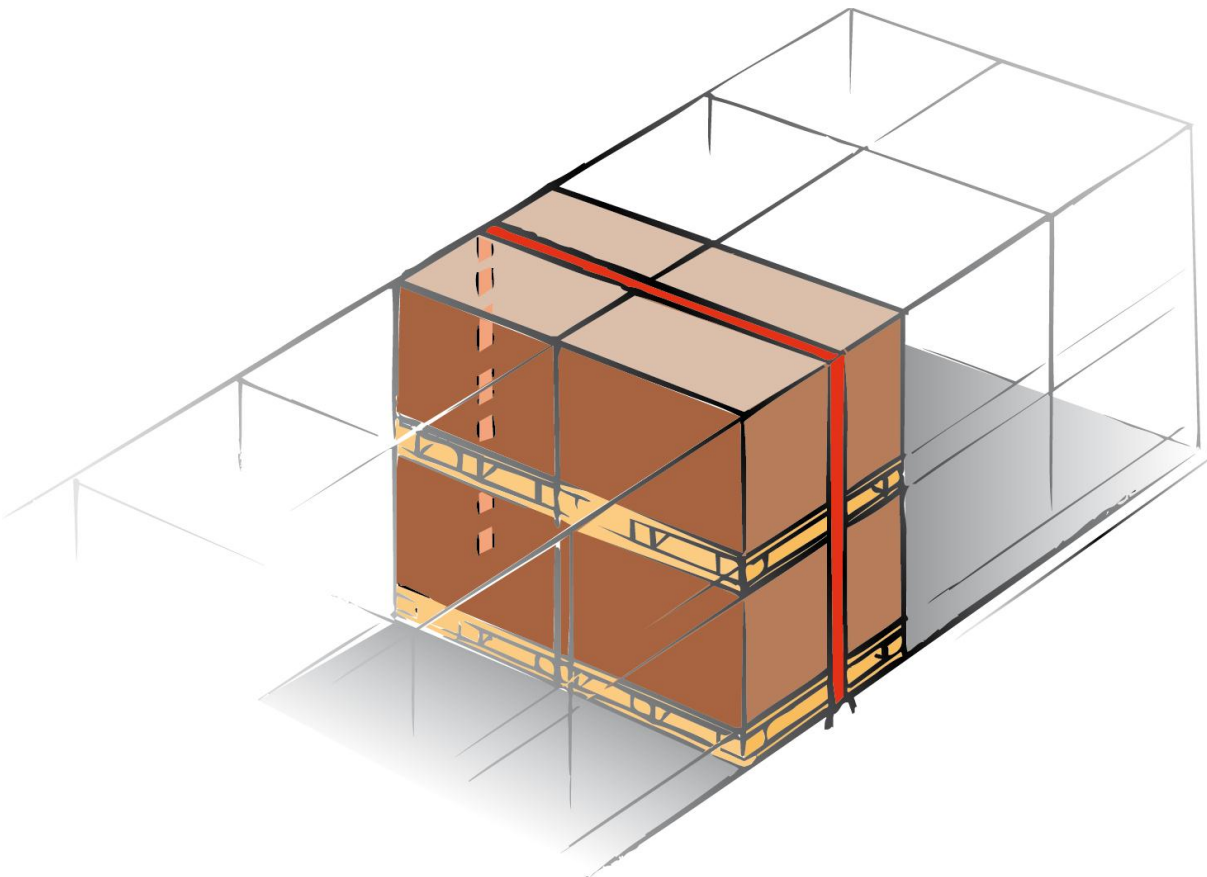

## A.2.14 Other types of cargo

### Rolling goods

You must prevent rolling goods from moving by using wedges or similar restraints.

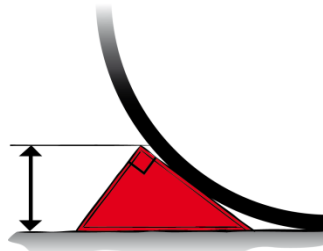

### Non-rigid goods

If the goods are not rigid, then more cargo restraints will need to be used than is shown in this guide.



## Appendix 3 Friction factors

Extract of EN12195-1:2010, normative annex B

Combination of materials in the contact surface (a)	Friction factor $\mu$
<b>Sawn wood</b>	
Sawn wood – fabric base laminate/plywood	0,45
Sawn wood – grooved aluminium	0,4
Sawn wood – shrink film	0,3
Sawn wood – stainless steel sheet	0,3
<b>Plane wood</b>	
Plane wood – fabric base laminate/plywood	0,3
Plane wood – grooved aluminium	0,25
Plane wood – stainless steel sheets	0,2
<b>Plastic pallet</b>	
Plastic pallet – fabric base laminate/plywood	0,2
Plastic pallet – grooved aluminium	0,15
Plastic pallet – stainless steel sheet	0,15
<b>Steel and metal</b>	
Steel crate – fabric base laminate/plywood	0,45
Steel crate – grooved aluminium	0,3
Steel crate – stainless steel sheet	0,2
<b>Concrete</b>	
Concrete rough – sawn wood battens	0,7
Concrete smooth – sawn wood battens	0,55
<b>anti-slip mat</b>	
Rubber	0,6 (b)
Other material	as certified (c)
<p><sup>a</sup> It has to be ensured that the used friction factors are applicable to the actual transport. Surface, dry or wet but clean, free from oil, ice, grease. If the surface contacts are not swept clean, free from frost, ice and snow a friction factor larger than <math>\mu = 0,2</math> shall not be used. Special precautions should be taken for oily and greasy surfaces.</p> <p><sup>b</sup> may be used with <math>f_u = 1,0</math> for direct lashing</p> <p><sup>c</sup> When special materials for increased friction like skid-inhibiting mats are applied, a certificate for the friction factor <math>\mu</math> is required.</p>	

## Appendix 4 Assessment of deficiencies

Item	Deficiencies	Deficiencies assessment		
		Minor	Major	Dangerous
A	Transport packaging does not allow proper load securing	At discretion of inspector		
B	One or more load units are not properly positioned	At discretion of inspector		
C	The vehicle is not suitable for the loaded cargo (deficiency other than those <i>listed under item 10</i> )	At discretion of inspector		
D	Obvious defects of the vehicle superstructure (deficiency other than those <i>listed under item 10</i> )	At discretion of inspector		
<b>10</b>	<b>Suitability of the vehicle</b>			
<b>10.1</b>	<b>Front wall</b> (if used for the securing of cargo)			
10.1.1	Part-weakening rust damage or deformations, Part cracked risking the integrity of the cargo compartment		X	X
10.1.2	Insufficient strength (certificate or label if applicable) Insufficient height relevant to cargo carried		X	X
10.2.	<b>Board walls</b> (if used for the securing of cargo)			
10.2.1.	Part-weakening rust damage, deformations, insufficient condition of hinges or catches Part cracked; hinges or catches missing or inoperative		X	X
10.2.2.	Stayer insufficient strength (certificate or label if applicable) Insufficient height relevant to cargo carried		X	X
10.2.3.	Board wall planks, insufficient condition Part cracked		X	X
<b>10.3.</b>	<b>Rear wall</b> (if used for the securing of cargo)			
10.3.1.	Part-weakening rust damage, deformations, insufficient condition of hinges or catches Part cracked; hinges or catches missing or inoperative		X	X
10.3.2.	Insufficient strength (certificate or label if applicable) Insufficient height relevant to cargo carried		X	X
<b>10.4.</b>	<b>Stanchions</b> (if used for the securing of cargo)			
10.4.1.	Part-weakening rust damage, deformations or insufficient attachment to vehicle Part cracked; attachment to vehicle instable		X	X
10.4.2.	insufficient strength or design Insufficient height relevant to cargo carried		X	X
<b>10.5.</b>	<b>Lashing points</b> (if used for the securing of cargo)			
10.5.1.	insufficient condition or design not capable of bearing required lashing forces		X	X
10.5.2.	Insufficient number Insufficient number for bearing required lashing forces		X	X
<b>10.6.</b>	<b>Required special structures</b> (if used for the securing of cargo)			
10.6.1.	Insufficient condition, damaged Part cracked; not able to bear restraint forces		X	X
10.6.2.	Not suitable for transported cargo missing		X	X
<b>10.7.</b>	<b>Floor</b> (if used for the securing of cargo)			
10.7.1.	Insufficient condition, damaged Part cracked; not able to bear cargo		X	X
10.7.2.	Insufficient load rating not able to bear cargo		X	X

Item	Deficiencies	Deficiencies assessment		
		Minor	Major	Dangerous
<b>20</b>	<b>Restraining Methods</b>			
<b>20.1.</b>	<b>Locking, blocking and direct lashing</b>			
<b>20.1.1</b>	<b>Direct attachment of the load (Blocking)</b>			
20.1.1.1	Distance forward to the front wall if used for direct securing of cargo too great More than 15 cm and danger of penetrating the wall		X	X
20.1.1.2.	Lateral distance to the board wall if used for direct securing of cargo too great More than 15 cm and danger of penetrating the wall		X	X
20.1.1.3.	Distance backwards to the rear board wall if used for direct securing of cargo too great More than 15 cm and danger of penetrating the wall		X	X
<b>20.1.2.</b>	<b>Securing devices such as lashing rails, blocking beams, battens and wedges to the front, to the sides and to the rear</b>			
20.1.2.1.	Improper attachment to vehicle Insufficient attachment Not able to bear restraint forces, loose	X	X	X
20.1.2.2.	Securing improper Insufficient securing Completely in-effective	X	X	X
20.1.2.3.	Insufficient suitability of the securing equipment Securing equipment complete unsuitable		X	X
20.1.2.4.	Suitability of the chosen method for securing the packaging suboptimal Chosen method complete inadequate		X	X
<b>20.1.3</b>	<b>Direct securing with nets and blankets</b>			
20.1.3.1.	Condition of the nets and blankets (Label missing/damaged but device still in good order) Load-restraint devices damaged Load-restraint devices seriously deteriorated and no longer suitable for use	X	X	X
20.1.3.2.	Insufficient strength of the nets and blankets Capability less than 2/3 of required_restraint forces		X	X
20.1.3.3.	Insufficient fastening of the nets and blankets Fastening less capable to bear 2/3 of required_restraint forces		X	X
20.1.3.4.	Insufficient suitability of the nets and blankets for securing the cargo Completely unsuitable		X	X
<b>20.1.4.</b>	<b>Separation and padding of the loading units or clearance spaces</b>			
20.1.4.1.	Suitability of the separation and padding unit Extensive separation or clearance spaces		X	X
<b>20.1.5.</b>	<b>Direct lashing (horizontal, transverse, diagonal, loop and spring lashings)</b>			
20.1.5.1.	The required securing strengths inadequate Less than 2/3 of required strength		X	X

Item	Deficiencies	Deficiencies assessment		
		Minor	Major	Dangerous
<b>20.2.</b>	<b>Friction-lock securing</b>			
<b>20.2.1.</b>	<b>Attainment of the required securing strengths</b>			
20.2.1.1.	The required securing strengths inadequate Less than 2/3 of required strength		x	x
<b>20.3.</b>	<b>Load-restraint devices used</b>			
20.3.1	Suitability of the load-restraint devices Completely unsuitable device		x	x
20.3.2.	Label (e.g. patch/test trailer) is missing/damaged but device still in good order Label (e.g. patch/test trailer) is missing/damaged but device shows considerable deterioration	x	x	
20.3.3.	Load-restraint devices damaged Load-restraint devices seriously deteriorated and no longer suitable for use		x	x
20.3.4.	Lashing winches, incorrect used Defective lashing winches		x	x
20.3.5.	Use of the load-restraint wrong (e.g. absence of edge protection) Use of the load-restraint devices defective (e.g. knots)		x	x
20.3.6.	Fastening of the load-restraint devices inappropriate Less than 2/3 of required strength		x	x
<b>20.4.</b>	<b>Additional equipment</b> (e.g. anti-slip mats, edge protectors, edge slides)			
20.4.1.	Unsuitable equipment used Wrong or defective equipment used Equipment used completely unsuitable	x	x	x
<b>20.5.</b>	<b>Transport of bulk material, light and loose material</b>			
20.5.1.	Bulk material blown away during operation of the vehicle on the road likely to distract traffic Posing a danger to traffic		x	x
20.5.2.	Bulk materials are not adequately secured Loss of cargo posing a danger to traffic		x	x
20.5.3.	Absence of covering for light goods Loss of cargo posing a danger to traffic		x	x
<b>20.6.</b>	<b>Round timber transports</b>			
20.6.1.	Transport material (logs) is partially loose			x
20.6.2.	Securing strengths of the loading unit inadequate Less than 2/3 of required strength		x	x
<b>30</b>	<b>Load entirely unsecured</b>			x